

Low-voltage power distribution and control systems > Switchgear >

# Magnum PXR low-voltage switchgear

## Contents

<b>General Description</b> .....	<b>20.7-2</b>
Product Description .....	20.7-2
<b>Devices</b> .....	<b>20.7-9</b>
Circuit Breakers .....	20.7-9
Metering Devices .....	20.7-17
Communications .....	20.7-18
Automatic Transfer .....	20.7-18
High-Resistance Grounding .....	20.7-19
Surge Protection Devices .....	20.7-21
<b>Layouts and Dimensions</b> .....	<b>20.7-22</b>
Breaker Layouts .....	20.7-22
Structure Dimensions .....	20.7-30
<b>Application Details</b> .....	<b>20.7-35</b>



*Powering Business Worldwide*



More about this product  
[Eaton.com/MagnumPXR](https://Eaton.com/MagnumPXR)



Complete library of design guides  
[Eaton.com/designguides](https://Eaton.com/designguides)

## Product Description

### Rear-Access Switchgear



Rear-Access Switchgear

### Product Offering

- UL® 1558
- CSA® C22.2 No. 31-10
- 1600–10,000 A bus
- 800–6000 A breakers
- 100 and 150 kA bus designs
- 600 Vac design
- Indoor enclosures
- Outdoor aisle and aisleless enclosures

### Application Description

- Healthcare
- Commercial construction
- Machine building
- Infrastructure
- Data centers
- Mining, minerals and metals
- Education
- Oil and gas
- Electric utilities
- Pulp and paper
- Industrial and manufacturing
- Food and beverage
- Transportation
- Government
- Water/wastewater

### Features and Benefits

- **Improved uptime**  
Higher interrupting ratings and withstand ratings, better coordination capability
- **Improved maintainability**  
Dedicated secondary terminals with separate access door and front-accessible control wireway
- **Increased reliability**  
Modular design allows for reduced parts for both structures and breakers
- **Increased safety**  
Complete enhanced performance suite of options
- **Reduced installation cost**  
Front-accessible controls and wiring enables rapid installation and commissioning

### Optional Features

#### Automatic Transfer and Intelligent Control

Increase uptime and simplify switchgear design by specifying one of Eaton’s pre-engineered automatic transfer and intelligent control packages for Magnum™ PXR low-voltage switchgear. The packages are designed with features to meet typical customer applications while still maintaining the flexibility to meet specific requirements. The packages are available on front and rear access in standard and arc-resistant designs.

#### Enhanced Safety

##### Integral Motorized Remote Racking (MR2)

First of its kind in the low-voltage switchgear realm, the Magnum MR2 provides an option for the breaker and cell to come equipped with a remote racking mechanism completely internal to switchgear, allowing users to rack the breaker in and out without having to step into the arc flash zone to equip an external device.

##### Zone Selective Interlocking

The Power Xpert® Release (PXR) zone selective interlocking (ZSI) capability provides positive system coordination without time delays. ZSI allows the breaker closest to the fault to trip without any preset time delay.

##### Arcflash Reduction Maintenance System™

Eaton’s Arcflash Reduction Maintenance System (ARMS) employs a separate, dedicated analog trip circuit that eliminates microprocessor latencies, resulting in clearing times that are faster than standard instantaneous tripping.

### Integrated High Resistance Grounding

High resistance grounding can add the safety of a grounded system while minimizing the risk of service interruptions due to grounds.

### GearGard™ for low-voltage switchgear

Optional environmental sensing and protection package that provides alarms regarding abnormal environmental conditions. The system will activate heaters, online and offline, when the system is nearing the dew point and at risk of condensation. The system also provides the operating environment condition level for using with maintenance plans that follow NFPA 70B.

### Thermal Monitoring

An optional, more budget-friendly version of GearGard that is focused only on continuous thermal monitoring allows users to detect potential issues before they become a problem, as well as detect intermittent issues that are missed using standard infrared windows by having monitoring 24/7.

### Standards and Certifications

- Assembly designed to UL 1558, CSA, IEEE® C37.20.1 and ANSI C37.51
- Breaker designed to UL 1066, IEEE C37.13, C37.15 and C37.17
- Seismic Certified to UBC, IBC and California Building Code to exceed Zone 4
- ABS certified

### Ratings

Table 20.7-1. Voltage Ratings (AC)

System Voltage	Maximum Voltage
208/240	254
480	508
600	635

Table 20.7-2. Available Bus Ratings

Cross Bus Ampacity	Bus Bracing kA
1600	100, 150
2000	
3200	
4000	
5000	100, 150
6000	
8000	
10,000	

## General Description

**Overview**

Eaton's Magnum PXR switchgear is backed by 70 years of switchgear development that has set the industry standard for quality, reliability, maintainability and extended operating life, when it comes to protecting and monitoring low-voltage electrical distribution systems. Magnum PXR switchgear is designed to meet the changing needs of our customers by providing:

- Lower installation and maintenance costs
- Higher interrupting ratings and withstand ratings
- Better coordination capability
- Increased tripping sensitivity
- Enhanced safety measures
- Higher quality, reliability and maintainability
- Communications and power quality monitoring and measuring capabilities
- Flexible layouts that maximize use of capital by minimizing equipment footprint

Magnum PXR switchgear can meet the needs of general applications, service entrances, harsh environments, multiple source transfers, special grounding systems and many others.

With a modern design, Magnum PXR metal-enclosed low-voltage switchgear and Magnum circuit breakers with Power Xpert Release trip units provide:

- 100% rated, fully selective protection
- Integral microprocessor-based breaker tripping systems
- Easy to set up pickups, timers and other functions via programming on the front LCD screen with navigation arrows, or through the micro-B USB connection and the Power Xpert Protection Manager (PXPM) software
- No need for external test kits with secondary injection testing via PXPM
- Two-step stored-energy breaker closing
- Standard 100 kA short-circuit bus bracing
- Optional 150 kA short-circuit bus bracing
- Optional metal barriers to isolate the cable compartment from the bus compartment
- Both indoor and outdoor aisle and aisleless enclosures
- Full range of safety solutions dealing with arc flash hazard and operator error



*Magnum PXR Switchgear*

Many other features for coordinated, safe, convenient, trouble-free, and economical control and protection of low-voltage distribution systems are also provided.

Magnum circuit breakers with PXR are designed to:

- IEEE Standards C37.13, C37.16, C37.17
- ANSI Standard C37.50
- UL 1066
- CSA C22.2 No. 268

Magnum PXR switchgear conforms to the following standards:

- CSA C22.2 No. 31-10
- IEEE C37.20.1
- ANSI C37.51
- UL 1558 and UL 891
- American Bureau of Shipping (ABS)
- Built in an ISO® certified facility

Maximum ratings for Magnum PXR switchgear are 600 Vac, 10,000 A continuous cross bus and 100 kA short-circuit capacity.

**Seismic Qualification**

Refer to [www.eaton.com/seismic](http://www.eaton.com/seismic) for information on seismic qualification for this and other Eaton products.

## Structure Features

**Standard finish:** Gray paint finish (ANSI 61) using a modern, completely automated and continuously monitored electrostatic powder coating. This continually monitored system includes spray de-grease and clean, spray rinse, iron phosphate spray coating spray rinse, non-chemical seal, oven drying, electrostatic powder spray paint coating and oven curing.

**Integral base:** The ruggedly formed base greatly increases the rigidity of the structure, reduces the possibility of damage during the installation of the equipment, and is suitable for rolling, jacking and handling. A lifting angle is permanently welded into the bus compartment structure for increased strength. The bottom frame structure members are indented to allow the insertion of a pry bar.

**Heavy-duty door hinges:** Each breaker door is mounted with hinge pins. Removal of the door is easily accomplished by just lifting the hinge pin. This allows easy access to the breaker internal compartment for inspection and maintenance.

**Rear cover/doors:** In Magnum PXR switchgear, standard rear bolted covers are provided. They are split into two sections to facilitate handling during removal and installation. Optional rear doors are also available.

**Through-the-door design:** The following functions may be performed without the need to open the circuit breaker door— lever the breaker between positions, operate manual charging system and view the spring charge status flag, close and open breaker, view and adjust the trip unit and read the breaker rating nameplate. Through-the-door Kirk keys further increase safety and provide interlocking capability.



*Through-the-Door Design*

**Cassette design:** The breaker cassette supports the breaker in the cell, as well as on the movable extension rails when the breaker is placed into or removed from the cell. The extension rails allow the breaker to be drawn out without having to de-energize the entire switchgear lineup.

**Accessibility:** When the door is open or removed, each breaker compartment provides front access to isolated, vertical wireways, primary disconnects, cell current transformers and other breaker compartment accessories for ease of field wiring and troubleshooting field connections.

**Four-position drawout:** Breakers can be in connected, test, disconnected or removed position. The breaker can be moved between the connected, test and disconnected positions while the compartment door is closed.

**Closing spring automatic discharge:** Mechanical interlocking automatically discharges the closing springs when the breaker is moved from the test to disconnect position.

**Optional safety shutters:** Positive acting safety shutters that isolate the breaker connections to the main bus when the breaker is withdrawn from the cell is an option offered for additional safety beyond our standard design. They reduce the potential of accidental contact with live bus. Insulating covers (“boots”) are furnished on live main stationary disconnecting contacts in compartments equipped for future breakers.

**Breaker inspection:** When withdrawn on the rails, the breaker is completely accessible for visual inspection; tilting is not necessary. The rails are permanent parts of every breaker compartment.

**Interference interlocks:** Supplied on breakers and in compartments where the compartments are of the same physical size. Interference interlocks ensure an incorrect breaker cannot be inserted.

**Optional key interlock (switchgear mounted):** This mechanism holds the breaker cell mechanically trip-free to prevent electrical or manual closing. Breaker can be stored in compartment, and completely removed for maintenance or for use as a spare without disturbing the interlock. Modification of the breaker is not required.

### Bus Features

**Buses and connections:** Vertical and cross bus ratings in Magnum PXR switchgear are based on a UL and IEEE standard temperature rise of 65 °C above a maximum ambient air temperature of 40 °C.

**Bus ampacities:** Vertical and main bus ratings in Magnum PXR are 1600, 2000, 3200, 4000 and 5000 A. In addition, a 6000, 8000 and 10,000 A main bus rating is available. Vertical section bus is sized per main cross bus maximum rating or by IEEE C37.20.1 to a maximum of 5000 A.

**Bus bracing:** Standard bracing is 100 kA. The “U” shaped bar is the heart of the Magnum PXR vertical bus. This configuration provides a much higher mechanical strength. To further demonstrate the strength and rigidity of this bus system, it has been verified through testing to withstand 85 kA short-circuit for a full 60 cycles.

**Silver and tin plating:** Bolted, silver-plated copper bus is standard. The plating is over the entire length of the bar, not just at the joints. Optional tin-plated copper bus is available.

**Bus joints:** All joints are bolted and secured with Belleville-type spring washers for maximum joint integrity. These washers reduce the potential of joint hardware loosening during the change of joint temperature associated with variations of the loads. Optional maintenance-free hardware is also available.

**Full neutral:** For four-wire applications, the neutral bus is rated 100% of main bus rating as standard. Neutral ratings up to a maximum of 10,000 A are available as an option. Additionally, four-pole breakers can be used in conjunction with four-wire systems.

**Ground:** A ground bus is furnished the full length of the switchgear assembly and is fitted with terminals for purchaser's connections.

**Glass reinforced polyester standoff insulation system:** Glass reinforced polyester has been used on both low and medium voltage switchgear for decades. By combining this industry-proven material with insulation, a total system providing exceptional mechanical and dielectric withstand strength, as well as high resistance to heat, flame and moisture, is produced. Substantial testing to demonstrate accelerated effects of heating and cooling on the mechanical and dielectric properties of this system prove it to provide superior performance for decades of trouble-free operation.

**Optional epoxy bus coating:** For applications requiring additional bus protection in harsh environments, Magnum PXR switchgear is designed for the addition of optional conductor insulation covering, in addition to providing full UL air clearance without insulation. This material is applied during the assembly of the bus, and covers all vertical and horizontal phase bus bars. Removable boots provide access to section-to-section bus joints for inspection and maintenance purposes.

**Barriers:** Optional grounded metal barriers isolate the main bus and connections from the cable compartment providing added safety to the workers while reducing the potential of objects falling into the bus compartment. In addition, vertical barriers between cable sections can be added to reduce potential hazards. Barriers are removable to give access to the bus compartment for inspection and maintenance. Barriers can be either solid metal or vented for ease of infrared scanning.



*Optional Bus Compartment and Vertical Section Barriers*



*Optional Insulated Bus*

## Wiring Features

**Cable compartment:** The cable compartment gives ample room for terminating the power cables. Removable top roof sheets allow for easy conduit hub installation. The floor of the cable compartment is open to allow cable entry from underground duct banks. Optional floor plates are available.

In addition to cable, Pow-R-Way® busway and nonsegregated bus duct can be terminated in the compartment.

**Lug pad:** The lugs are located on the breaker run-backs to accommodate lug orientations at a 45° angle to reduce the bending radius of the cable needed for making the connections, thus reducing installation and maintenance time. Mechanical setscrew type lugs are standard. Optional NEMA two-hole compression lugs are available as an option.

**Control wireway:** An isolated vertical wireway is provided for routing of factory and field wiring in each switchgear section. Breaker secondary terminal blocks are mounted as standard above each circuit breaker. The terminal blocks are rated 30 A, and will accept bare wire, ring or spade terminals for wire size ranges of #22–#10. Extruded loops are punched in side sheets of the vertical wireway to allow securing of customer control wiring without the use of adhesive wire anchors.

Control circuits may be wired in all cells without removing the circuit breaker. In addition, power circuits may be connected in the rear of the switchgear at the same time control circuits are being wired in the front of the switchgear.

**Control wire:** Standard wire is Type SIS insulated stranded copper, extra flexible No. 14 AWG minimum. Type VW-1 wire is available.

**Control wire marking:** Each wire is imprinted with ink cured under ultraviolet light for durability and for easy identification by the user. The enhanced solvent resistance and durability of the aerospace grade UV cure ink has been tested for severe environments. The imprinting is made every 3.00 inches (76.2 mm) along the length of the wire to make field troubleshooting easier. The point of origin, wire designation and point of destination are imprinted in the following format: <origin zone/wire name/destination zone>.

Each device has a uniquely designated zone. "<" indicates the direction of the wire origination and ">" indicates the direction of the wire destination. As an option, wire name marking can be made using sleeve type or heat shrink sleeve type.



**Control Wire Marking**

**Secondary terminal compartment:** There are 84 finger-safe secondary connections for a standard and double-frame Magnum PXR breaker and 72 for a narrow-frame Magnum PXR breaker. The customer's secondary terminal connections are located at the front of the structure behind a separate door providing access to these connections without the need to open the breaker compartment door. The additional updated connections also serve as a rejection feature from the previous Magnum circuit breaker designs.

**Short-circuiting terminal blocks:** One provided for each set of instrumentation or relaying application current transformers.

**Shipping split connection:** At each shipping split, the control connections are made with plug-in terminal blocks rated 600 V, 30 A. The terminal blocks mechanically interlock without removing the line or load connections. This method of making the shipping split control connections increases the speed of installation and reduces the potential of incorrect connections.

## Instrumentation/Metering Features

**Flexibility:** Magnum PXR switchgear allows for a variety of metering options.

See [www.eaton.com/meters](http://www.eaton.com/meters) for Metering and Power Management products.

- Analog switchboard type meters such as ammeters and voltmeters
- Electronic power metering such as the Power Xpert Quality (PXQ) event analysis system and Power Xpert Energy (PXE) meters
- Panels for ease of visibility

**Voltage transformers:** Voltage transformers are rated 10 kV BIL, and are protected by both primary and secondary fuses. The primary fuses are of the current-limiting type.

**Current transformers:** Current transformers for metering and instrumentation are mounted in the breaker compartments and are front accessible. Secondary wiring between the current transformer and the standard shorting terminal block is color-coded for ease of identification. Bus mounted CTs are available for metering and relaying.

**Control power transformers:** Control transformers are provided when required for AC control of circuit breakers, space heaters and/or transformer fans. Like voltage transformers, they are protected by current-limiting primary fuses. Supplemental fuses and circuit breakers are used on the secondary side to protect miscellaneous circuits.

**Instrument compartment door:** Devices, such as electronic power metering and analog switchboard type meters that do not fit on the secondary terminal compartment door, are mounted on the instrument compartment door or on a panel of a blank cell.

**Instrumentation/Metering**

**Features, continued**

**Instrumentation—secondary terminal compartment door:** Devices, such as control pushbuttons, indicating lights, switches and analog meters can be mounted on these panels, within space limitations.



*Devices Mounted on Secondary Terminal Compartment Door*

**Accessories and Options**

**Switchgear accessories:** Standard accessories furnished with each Magnum PXR switchgear assembly include:

- One breaker racking tool
- Insulating covers or “boots” furnished on live main stationary disconnecting contacts in compartments equipped for future breakers
- Removable cover to block opening in the door when the breaker is temporarily removed from its compartment



*Magnum Shutter Module*

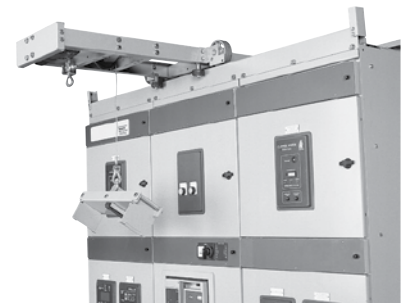

*Optional Switchgear Mounted Lifter*

**Optional Accessories**

- Traveling type circuit breaker lifter, rail-mounted on top of switchgear
- Floor-running portable circuit breaker lifter and transfer truck with manual lifting mechanism. This requires approximately 84.00 inches (2133.6 mm) deep front aisle space
- Test cabinet for electrically operated breakers, with pushbuttons, control cable and receptacle, for separate mounting
- Optional space heaters to be placed in the bottom of the breaker, cable and bus compartments. Space heaters are provided as standard in outdoor gear to reduce condensation
- Remote racking device (MRR1000) for both breaker racking and operation (open/close) from a safe distance. Mounts to any existing Magnum PXR breaker. Uses standard 120 V, 15 A, single-phase, 60 Hz supply
- Shutter module provides an easy method of open/closing shutters to test them
- Cable lashing device kits simplify cable lashing requirements with speed and ease, reducing cable lashing time by more than 20 minutes per circuit breaker



*MRR1000 Remote Racking Device*

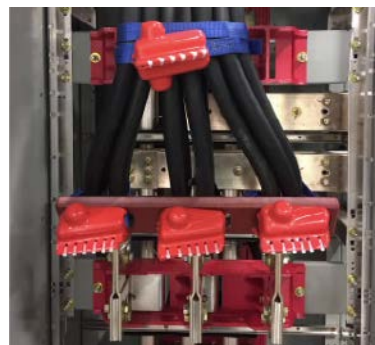

*Cable Lashing Device*

General Description

**Enhanced Switchgear Options**

- Optional integrated motorized remote racking device (MR2) can be installed on any breaker and controlled either through a PXG1000 with the remote racking application installed or a remote pendant
- Optional environmental sensing and protection package that provides alarms regarding abnormal environmental conditions—the system will activate heaters, online and offline, when the system is nearing the dew point and at risk of condensation; the system also provides the operating environment condition level for using with maintenance plans that follow the 2023 revision of the NFPA 70B standard
- Infrared scanning windows for thermal scans of lug landings
- Optional thermal monitoring system to allow users to detect potential issues before they become a problem, as well as detecting intermittent issues that are missed using standard infrared windows by having monitoring 24/7
- Maintenance-free (Torque-&-Forget) bus hardware
- Grounding balls and covers for protecting maintenance personnel downstream of switchgear feeder breakers
- Pendant for remote open and close of electrically operated breakers



**Grounding Balls and Covers**



**Magnum MR2 with Pendant**



**Remote Control Pendant**

## Circuit Breakers

Eaton's Magnum power circuit breakers with Power Xpert Release trip units constitute a complete, modern and rugged line of low-voltage power circuit breakers using Eaton's DE-ION® principle of arc extinction. The breaker family is distinguished by its similarity of appearance and operation frame to frame. All frame sizes are either manually or electrically operated. Refer to <https://www.eaton.com/MagnumPXR> for detailed information on Magnum circuit breakers with Power Xpert Release trip units.

## Breaker Features

### Four Physical Frame Sizes

Narrow, standard, double narrow and double standard to promote breaker application in compact modular enclosures and to improve enclosure density.

### Contacts

Magnum PXR has silver tungsten moving contacts and silver graphite stationary contacts. The contacts provide a long-wearing, low-resistance joint. The contacts are protected from arcing damage even after repeated interruptions by the "heel-toe" action, which causes the integral arcing contacts to mate before the main contacts part. The arcing contacts then part last, striking the arc away from the main contacts.

The main contacts are of the butt type and are composed of multiple fingers to give many points of contact without alignment being critical.

### Stored-Energy Mechanism

A cam-type closing mechanism closes the breaker. It receives its energy from a spring that can be charged by a manual handle on the front of the breaker or by a universal electric motor.

Release of the stored energy is accomplished by manually depressing a button on the front of the breaker or electrically energizing a releasing solenoid.



**Magnum PXR Circuit Breakers have High Withstand Ratings from 42 to 100 kA to Provide for Maximum System Coordination and Selectivity**

## Arc Chute

There are three basic means of extinguishing an arc: lengthening the arc path; cooling by gas blast or contraction; deionizing or physically removing the conduction particles from the arc path.

The DE-ION principle is incorporated in all Magnum circuit breakers with PXR. This makes faster arc extinguishing possible for a given contact travel, ensures positive interruption and minimum contact burning.

## Levering Mechanism

The worm gear levering mechanism is self-contained on the breaker drawout element and engages slots in the breaker compartment. A standard 3/8-inch (10 mm) drive set is used to lever the breaker between the connected, test and disconnected positions.

Mechanical interlocking is arranged so that levering cannot be accomplished unless the breaker is in the opened position.

## Protection During Levering Operation

When levering the breaker between the connected, test and disconnected positions, the operator is protected from contact with live parts by the breaker door.

## True two-step stored energy closing:

Refers to the sequence required to charge and close the breaker.

1. The breaker closing springs are charged either through the manual-charging handle or by the optional charging motor. The breaker is mechanically interlocked to prevent closing of the breaker until the closing springs are fully charged.
2. With the closing springs fully charged, the breaker can then be closed by pressing the manual close pushbutton on the breaker, or by the optional spring release coil through a remote electrical signal.

“Stored energy” is energy held in waiting, ready to open or close the breaker within five cycles or less. The unique cam and spring design provides necessary energy for a single close-open sequence as well as the energy for multiple charge-close operations such as this possible sequence: charge-close-recharge-open-close-open.

This means that the energy required to open the breaker is always restored following a closing operation.

The closing springs are interlocked with the breaker racking mechanism to ensure the closing springs are discharged before the breaker reaches the disconnect position.

**Provisions for padlocking:** All breakers include provision for padlocking open to prevent electrical or manual closing. This padlocking can secure the breaker in the connected, test or disconnected position by preventing levering of the breaker.

**Ease of inspection and maintenance:** Magnum circuit breakers with PXR are designed for maximum accessibility and the utmost ease of inspection and maintenance. The PXR trip unit includes an innovative algorithm to monitor the health of the circuit breaker to provide an overall picture of the condition of the breaker.

**Manually operated breakers:** Manually operated breakers are equipped with a manual charging handle to charge the closing springs. Manual closing and tripping pushbuttons are used to operate the breaker. Remote closing and tripping can be accomplished by installing optional electric spring release and shunt trip coils. The breaker closing springs must be charged manually, then remote closing and tripping signals can be sent to the breaker.

**Electrically operated breakers:** Electrically operated breakers are equipped with a spring charging motor and electrically operated spring release and shunt trip coils. The breaker manual charging handle can be used to charge the closing springs when power is not available to the charging motor.

### Optional Breaker Accessories

- **Shunt trip device (ST):** Provides for remote electrically controlled breaker opening when energized by a rated voltage input
- **Spring charge motor (MOT):** Charges the breaker closing springs automatically, facilitating remote or local closing. The motor assembly includes its own cut-off switch that changes state at the end of the charging cycle. This contact can be wired out for external indication
- **Spring release device (SR):** Provides for remote electrically controlled breaker closing when its coils are energized by a rated voltage input
- **Undervoltage release (UVR):** Trips the breaker when an existing voltage signal is lost or falls below an established threshold
- **Auxiliary switch:** Up to 12 Form C auxiliary individual dedicated contacts are available for customer use to indicate if the breaker is in the OPEN or CLOSE position
- **Mechanical trip indicator flag:** The red trip indicator flag pops out to provide local visual indication when the PXR trip unit acts to trip the breaker on an overcurrent condition. Available in two options: an interlocked version that mechanically locks out the breaker until the indicator is manually reset and a non-interlocked version for indication only
- **Overcurrent trip switch (OTS):** Provides two Form C contacts that change state when the PXR trip unit acts to trip the breaker. The contacts are available for external indication or customer use and are manually reset by the mechanical trip indicator
- **Padlockable pushbutton cover:** Permits padlocking hinged cover plates to block access to the CLOSE and OPEN buttons on the breaker faceplate
- **Mechanical operations counter:** Records mechanical operations of the breaker over its installed life
- **Latch check switch:** Provides one Form C contact that changes state when the breaker is ready to close. Can be internally wired to the spring release device for fast transfer applications or wired for external ready-to-close indication
- **Magnum MR2 integral racking:** Magnum PXR or Power Defense SB (PD-SB) drawout breakers with the MR2 integral racking option allow an operator to remotely rack a Magnum breaker from a distance of 30 ft (9.14 m) or greater depending on the communication option installed. The MR2 helps to mitigate electrical arc flash exposure by allowing the operator to work from outside the arc flash boundary. The integral racking system consists of a breaker with integral motorized racking assembly, wired cassette, controller and a customer-provided user interface. The racking assembly contains safety and component position sensing features located on the racking mechanism of the breaker. The controller accepts 120 Vac and supplies power to a motor based on the user input. The position of the Magnum breaker is detected by three limit switches located internal to the racking mechanism

**Magnum PXR Switchgear—Trip Units**

**Power Xpert Release (PXR) trip unit,** along with current sensors and a trip actuator, is the subsystem of a circuit breaker that provides the protection, monitoring and metering functions. The PXR analyzes signals from the current sensors and voltage connections. If the current level and time delay settings are exceeded, then the PXR trip unit will initiate a trip of the circuit breaker. The automatic overload and short-circuit tripping characteristics for a specific circuit breaker are determined by the current rating and user-selected protection settings. A wide range of adjustments of the protection allow the breaker to be coordinated and adapted to any application. External control voltage is not required for current protection functionality. Additionally, all of the trip units have, as standard, thermal memory, 50/60 Hz operation and thermal self-protection at 95 °C.

**PXR integral microprocessor-based breaker overcurrent trip systems:** Provide maximum reliability with true rms sensing as standard, gives excellent repeatability and requires minimum maintenance. No external control source is required for its protective functions.

**Trip functions:** Magnum PXR trip units provide maximum flexibility and are available in the following configurations dependent on the PXR module chosen. For PXR 20, PXR 25 and PXR 35, LSI and LSI options are selectable. Please note that with the flexibility of the PXR trip units, the A letter is no longer needed as the ground fault functionality is completely programmable. In each case, either the short delay or instantaneous (not both) functions may be defeated. This reduces the need for spare breaker inventories and provides maximum usage of interchangeable breakers.

**PXR 20:** Enables the user as many as nine phase and ground current protection settings for maximum flexibility in trip-curve shaping and multi-unit coordination, and adds zone selective interlocking. Unit is programmable via dials on the front of the unit for the current protection functions. Additional settings are programmable through an LCD display with navigation buttons or via micro-B USB and Power Xpert Protection Manager (PXPM) software. Provides 0.5% accuracy current metering, ability to enable/disable ground fault, along with the Arcflash Reduction Maintenance System. Breaker health menu and Modbus RTU onboard communications are included.

**PXR 25:** Provides programmability for more sophisticated distribution systems.

- Increased protection and coordination capabilities to fine tune protection settings
- Systems monitoring information including power factor, voltage, current, harmonic distortion values, and waveform capture with an LCD display as well as downloadable with a micro-B USB connection and PXPM installed on a laptop
- Multiple programmable contacts for customer use (quantity changes based on double/standard versus narrow frames)
- Time stamping of trip events for improved troubleshooting and diagnostics
- Accuracy of 0.5% on current and voltage and 1% on energy and power
- Systems diagnostic information
- Breaker health menu
- Additional protection functions:
  - Undervoltage/overvoltage
  - Voltage unbalance
  - Reverse power
- Multiple communications options including Modbus TCP, PROFIBUS and PROFINET—Communication Accessory Modules (CAMs) currently not available in low-voltage switchgear, only Modbus via Power Distribution Monitoring and Control—Enhanced or PXG1000 is configured

**PXR 35:** Top-of-the-line trip unit that brings even higher accuracies with 0.25% metering on both voltage and current, which combine for a 0.5% power and energy metering accuracy.

- Improved breaker health algorithm aggregating more data than the PXR 20 and PXR 25
- Integrated Modbus TCP and IEC 61850 (GOOSE) communications
- Improved ZSI system by allowing trip unit coordination and troubleshooting
- Review events captured across multiple breakers using PXR 35 with Global Event Capture
- Additional protective functions:
  - Total harmonic distortion alarm
  - Phase rotation alarm
  - Over/under frequency
  - IEEE curves for long delay



PXR 20

PXR 25



PXR 35

**Zone selective interlocking:** The PXR zone selective interlocking (ZSI) capability provides positive system coordination without time delays. ZSI allows the breaker closest to the fault to trip without any preset time delay. The breaker closest to the fault trips first, while the remainder of the distribution system remains online, thus avoiding unnecessary and costly downtime.

**Arcflash Reduction Maintenance System (ARMS)**

The Arcflash Reduction Maintenance System Maintenance Mode function of the Power Xpert Release trip units can reduce arc flash incident energy that is generated on a fault condition. This is accomplished by a parallel trip circuit that, when armed, provides a fast-acting response to the fault. This is separate from the normal system protection setting of instantaneous. The PXR Arcflash Reduction Maintenance System Maintenance Mode operates at the same time as the normal LSIG protection. For most fault conditions as shown in the **Figure 20.7-1** time-current curve, the Arcflash Reduction Maintenance System protection will override the LSI protection and the normal LSIG protection provides an added backup function. Eaton’s Arcflash Reduction Maintenance System employs a separate, peak-sensing trip circuit that eliminates trip unit’s microprocessor latencies, resulting in clearing times that are faster than standard instantaneous tripping. This provides superior arc flash reduction compared to competitors’ systems that simply lower the standard instantaneous pickup set point or employ ZSI tripping.

There are three ways to arm the Maintenance Mode setting. One method is locally at the trip unit front panel. The PXR 20, PXR 25 and PXR 35 have a two-position switch on the front of the trip unit for the Maintenance Mode. Turning the switch to the ON position will locally arm the function.

For the second method, a remote switch or external relay contact wired through the breaker secondary terminals can remotely arm the Maintenance Mode protection function. A high-quality gold-plated or palladium contact is required in this application.

The third method is via a communication device. The trip unit display will show a confirmation screen that verifies the Maintenance Mode function has been set. A Power Distribution Monitoring and Control—Enhanced or basic version display interface module can be used as one of the communication methods to arm the protection function remotely from a safe distance.

The Arcflash Reduction Maintenance System setting has five unique settings (1.5, 2.5, 4.0, 6.0, 10.0 x  $I_n$ ) for the pickup of the reduction setting. This setting level can be used to prevent inrush currents or load surges from triggering the Maintenance Mode function. The PXR trip units are now able to go to a new lower setting of 1.5 X the frame rating  $I_n$  for the maximum reduction of arc flash energy. For all three arming methods, the PXR trip units provide a local indication as a blue LED ring around the ON/OFF switch to confirm the Maintenance Mode function is on or off. In addition, one of the three programmable relays in the frame module of the breaker can be set to indicate the status of the Maintenance Mode protection. This normally open relay contact allows the user to wire in an external stack light or annunciator for remote indication.

The Maintenance Mode function will provide fast tripping even when the regular Instantaneous is set to OFF. The instantaneous LED position is also used to indicate a trip initiated by the Maintenance Mode setting. The LCD display, if powered, will indicate the message Maintenance Mode Trip.

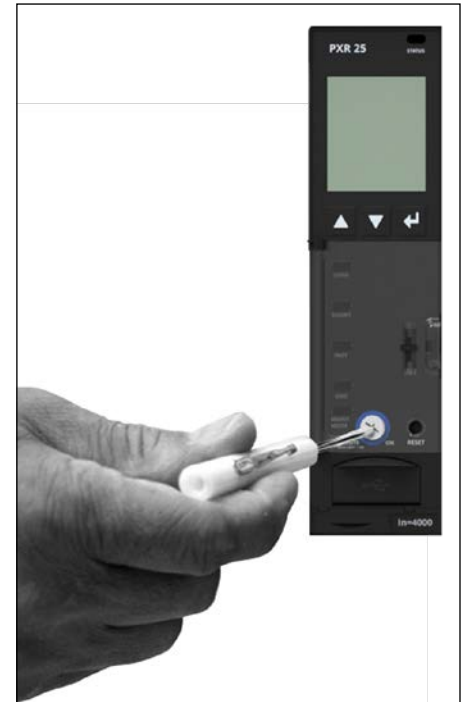

**Arcflash Reduction Maintenance System**

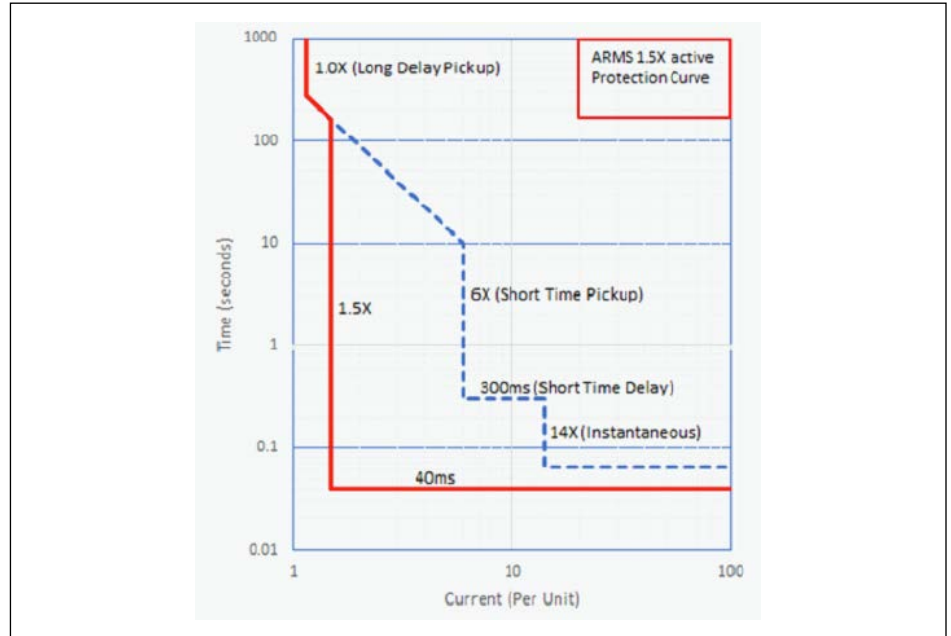

**Figure 20.7-1. Arcflash Reduction Maintenance System Time-Current Curve**

**Primary Protection Features**

The Time-Current Curves (TCC) for the PXR 20, PXR 25 and PXR 35, when used in Magnum PXR circuit breakers, are found in document TD013172EN. All protection settings shall be made by following the recommendations of the specifying engineer in charge of the installation.

**Table 20.7-3. Primary Protection Features**

Protection		PXR 20	PXR 25	PXR 35
Overload protection (Long delay) (L) ANSI 51P	Long delay slope		I <sup>2</sup> t	I <sup>2</sup> t, I <sup>4</sup> t, It, I <sup>1/2</sup> t
	Long delay pickup	x (I <sub>n</sub> )	0.4, 0.5, 0.6, 0.7, 0.75, 0.8, 0.9, 0.95, 0.98, 1.0	0.4 to 1.0 in steps of 0.01
	Long delay time at 6 x (I <sub>L</sub> )	Seconds	0.5, 1, 2, 4, 7, 10, 12, 15, 20, 24	0.5 to 24 ① in steps of 0.1
	Long delay thermal memory		Enable/disable	Enable/disable
	High load alarm 1	% x (I <sub>L</sub> )	OFF or 50% to < high load alarm 2 in steps of 1.0%	OFF or 50% to < high load alarm 2 in steps of 1.0%
	High load alarm 2	% x (I <sub>L</sub> )	OFF or > high load alarm 1 to 120% steps of 1.0%	OFF or > high load alarm 1 to 120% steps of 1.0%
	High load alarm time delay			1 to 60 seconds in steps of 1 second
Short circuit protection (S) ANSI 50TD ZSI ANSI 68	Short delay slope		Flat, I <sup>2</sup> t	Flat, I <sup>2</sup> t
	Short delay pickup	x (I <sub>L</sub> )	1.5, 2, 2.5, 3, 4, 5, 6, 7, 8, 10	1.5 to 10 in steps of 0.1
	Short delay time I <sup>2</sup> t at 8 x (I <sub>L</sub> )	Seconds	0.1, 0.3, 0.4, 0.5	0.05 to 0.5 in steps of 0.01
	Short delay time flat	Seconds	0.05, 0.1, 0.2, 0.3, 0.4, 0.5	0.05 to 0.5 in steps of 0.01
	Short delay zone interlock		Enable/disable	Enable/disable
Neutral protection ANSI 50N ANSI 51N	4th pole or external neutral	% x (I <sub>L</sub> )	OFF, 60, 100	OFF, 60, 100
	Pickup	x (I <sub>n</sub> )	OFF, 2 to 15 in steps of 0.1	OFF, 2 to 15 in steps of 0.1
Instantaneous protection (I) ANSI 50P	Instantaneous pickup	x (I <sub>n</sub> )	OFF, 2, 4, 5, 6, 7, 8, 10, 12, 15	OFF, 2 to 15 in steps of 0.1
	Making current release level determined by frame	A	Y	Y
Ground (earth) fault protection (G) ANSI 51G ZSI ANSI 68	Ground fault sensing		Residual, source ground or zero sequence	Residual, source ground or zero sequence
	Ground fault pickup ② – trip (I <sub>g</sub> )	x (I <sub>n</sub> )	0.2, 0.4, 0.6, 0.8, 1.0	0.2 to 1.0 in steps of 0.01
	Ground fault pickup ② – alarm	x (I <sub>n</sub> )	OFF, 0.2, 0.4, 0.6, 1.0	OFF, 0.2 to 1.0 in steps of 0.01
	Ground fault delay I <sup>2</sup> t at 0.625 x (I <sub>n</sub> )	Seconds	0.1, 0.2, 0.3, 0.5, 1.0	0.1 to 1 in steps of 0.01
	Ground fault delay flat	Seconds	0.05, 0.2, 0.3, 0.5, 1.0	0.05 to 1 in steps of 0.01
	Ground fault zone interlock		Enable/disable with ground fault pickup	Enable/disable with ground fault pickup
	Ground fault thermal memory		Enable/disable	Enable/disable
	Ground fault pre-alarm	%	50 to 100 of I <sub>g</sub> in steps of 1.0	50 to 100 of I <sub>g</sub> in steps of 1.0
Maintenance Mode protection (Arcflash Reduction Maintenance System) (A) ANSI 50	Switch positions		ON or remote LED lights when enabled	ON or remote LED lights when enabled
	Maintenance mode pickup ③	x (I <sub>n</sub> )	1.5, 2.5, 4.0, 6.0, 8.0, 10.0	1.5, 2.5, 4.0, 6.0, 8.0, 10.0
	Relay contact for remote indication of mode		Y	Y

① If I<sup>2</sup>t slope is selected not all times are available, consult time-current curves.  
 ② Ground fault pickup is limited to a maximum of 1200 A for ANSI/UL/CSA versions to comply NEC® standards.  
 ③ Maintenance mode pickup maximum setting may be limited based on rating I<sub>n</sub>.

Enhanced Protection Features

Table 20.7-4. Enhanced Protection Features

ANSI Standard	Enhanced Protection		Units	Settings	
<b>PXR 25</b>					
ANSI 59	Voltage protection	Overvoltage pickup	Volts	180 to 720 in steps of 1	Three modes of operation are selectable for these protection functions: OFF, Alarm or Trip
		Overvoltage delay	Seconds	1 to 300 in steps of 1	
ANSI 27	Voltage protection	Undervoltage pickup	Volts	60 to 670 in steps of 1	
		Undervoltage delay	Seconds	1 to 300 in steps of 1	
ANSI 47	Voltage protection	Voltage unbalance pickup	% Volts	5 to 25 in steps of 1	
		Voltage unbalance delay	Seconds	1 to 300 in steps of 1	
ANSI 46	Current protection	Current unbalance pickup	% Amps	5 to 25 in steps of 1	
		Current unbalance time	Seconds	1 to 300 in steps of 1	
ANSI 78V	Current protection	Phase loss pickup	% Amps	75	
		Phase loss delay	Seconds	1 to 240 in steps of 1	
ANSI 32R	Power protection	Reverse power pickup	kW	1 to 65,500 in steps of 1	
		Reverse power delay	Seconds	1 to 300 in steps of 1	
<b>PXR 35</b>					
ANSI 59	Motor protection ①	Over voltage pickup	% Volts	102 to 150 in steps of 0.1	
		Over voltage delay	Seconds	0.05 to 300 in steps of 0.05	
ANSI 27	Motor protection ①	Under voltage pickup	% Volts	50 to 98 in steps of 0.1	
		Under voltage delay	Seconds	0.05 to 300 in steps of 0.05	
ANSI 47	Motor protection ①	Voltage unbalance pickup	% Volts	2 to 90 in steps of 1	
		Voltage unbalance delay	Seconds	1 to 300 in steps of 0.05	
ANSI 46	Motor protection ①	Phase rotation (sequence) pickup	—	ABC or CBA	
		Current unbalance pickup	% Amps	2 to 90 in steps of 1	
		Current unbalance delay	Seconds	1 to 300 in steps of 0.05	
ANSI 78V	Motor protection ①	Phase loss pickup	% Amps	75	
		Phase loss delay	Seconds	1 to 240 in steps of 1	
ANSI 32R	Motor protection ①	Reverse power pickup	kW	1 to 65,500 in steps of 1	
		Reverse power delay	Seconds	0.05 to 300 in steps of 0.05	
		Reverse reactive power pickup	kvar	1 to 65,500 in steps of 1	
		Reverse reactive power delay	Seconds	1 to 300 in steps of 1	
ANSI 32P	Power protection ①	Real power pickup	kW	1 to 65,500 in steps of 1	
		Real power delay	Seconds	1 to 300 in steps of 1	
		Apparent power pickup	kVA	1 to 65,500 in steps of 1	
		Apparent power delay	Seconds	1 to 300 in steps of 1	
		Reactive power pickup	kvar	1 to 65,500 in steps of 1	
		Reactive power delay	Seconds	1 to 300 in steps of 1	
		Real power demand pickup	kW	1 to 65,500 in steps of 1	
		Apparent power demand pickup	kVA	1 to 65,500 in steps of 1	
ANSI 55	Power protection ①	Power factor pickup	—	0.2 to 0.95 in steps of 0.05	
		Power factor delay	Seconds	1 to 60 in steps of 1	
ANSI 810	Frequency protection ①	Over frequency pickup	% Hz	100.1 to 110 in steps of 0.1	
		Over frequency delay	Seconds	0.05 to 60 in steps of 0.05	
ANSI 81U	Frequency protection ①	Under frequency pickup	% Hz	90 to 99.9 in steps of 0.1	
		Under frequency delay	Seconds	0.05 to 60 in steps of 0.05	
	Total harmonic distortion alarm ②	Current pickup			
		Current delay	Seconds		1 to 60 in steps of 1
		Voltage pickup			10 to 30 in steps of 1
ANSI 25	Synchronism check ③	Min live line volt	% Vnom	10 to 130 in steps of 1	
		Max dead line volt	% Vnom	10 to 100 in steps of 1	
		Min live load volt	% Vnom	10 to 130 in steps of 1	
		Max dead load volt	% Vnom	1 to 100 in steps of 1	
		Max volt difference	% Vnom	1 to 5 in steps of 1	
		Max slip frequency	Hz	0.01 to 2 in steps of 0.01	
		Max angle difference	Degrees	1 to 60 in steps of 1	
	Volt dead time	Seconds	0 to 300 in steps of 1		

① Three modes of operation are selectable for these protection functions: OFF, Alarm or Trip.

② Two modes of operation are selectable for these protection functions: OFF or Alarm.

③ Can be mapped to a programmable relay and used in conjunction with the spring release.

**Current, Voltage, Frequency, Power and Energy Data**

The PXR 20, PXR 25 and PXR 35 provide real-time metering information regarding the loads being protected. The PXR 25 and PXR 35 include monitoring of voltage and phase angle to support power and energy data. All accuracy requires control power (AUX) to the trip unit and is specified for a three-phase balanced load.

**Table 20.7-5. Metering Data**

Description	Units	Accuracy
<b>Current Metering</b>		
IA, IB, IC, IN <sup>①</sup> , IG	Amperes	PXR 20 and PXR 25: ±0.5% of reading over the range of 10% to 120% x I <sub>n</sub> at 25 °C (77 °F) PXR 35: ±0.25% of reading over the range of 10% to 120% x I <sub>n</sub> <sup>②</sup> at 25 °C (77 °F)
Minimum IA, IB, IC, IN, IG	Amperes	
Maximum IA, IB, IC, IN, IG	Amperes	
THD for IA, IB, IC, IN	%	
Demand IA, IB, IC, IN, IG	Amperes	
Demand maximum IA, IB, IC, IN, IG	Amperes	
<b>Voltage Metering</b>		
VAB, VBC, VCA (line-to-line)	Volts	PXR 25: ±0.5% of reading over the range of 102 to 690 Vac line-to-line at 25 °C (77 °F) PXR 35: ±0.25% <sup>③</sup> of reading over the range of 102 to 690 Vac line-to-line at 25 °C (77 °F)
Minimum VAB, VBC, VCA	Volts	
Maximum VAB, VBC, VCA	Volts	
THD for VAB, VBC, VCA	%	
VAN, VBN, VCN (line-to-neutral)	Volts	
Minimum VAN, VBN, VCN	Volts	
Maximum VAN, VBN, VCN	Volts	
<b>Power Metering</b>		
Real	kW	PXR 25: ±1.0% of reading over the range of 20% to 120% x I <sub>n</sub> , 102 to 690 Vac line-to-line, and PF of 0.8 leading to 0.5 lagging at 25 °C (77 °F) PXR 35: ±0.50% of reading over the range of 10% to 120% x I <sub>n</sub> <sup>②</sup> , 102 to 690 Vac line-to-line, and PF of 0.8 leading to 0.5 lagging at 25 °C (77 °F)
Apparent	kVA	
Reactive	kvar	
Real demand	kW	
Apparent demand	kVA	
Reactive demand	kvar	
Real demand (peak)	kW	
Apparent demand (peak)	kVA	
Reactive demand (peak)	kvar	
<b>Energy Metering</b>		
Real total (forward + reverse)	kWh	PXR 25: ±1.0% of reading over the range of 20% to 120% x I <sub>n</sub> , 102 to 690 Vac line-to-line, and PF of 0.8 leading to 0.5 lagging at 25 °C (77 °F) PXR 35: ±0.50% of reading over the range of 10% to 120% x I <sub>n</sub> <sup>②</sup> , 102 to 690 Vac line-to-line, and PF of 0.8 leading to 0.5 lagging at 25 °C (77 °F)
Real net (forward – reverse)	kWh	
Real forward (delivered by source to load)	kWh	
Real reverse (delivered by load to source)	kWh	
Apparent energy	kVAh	
Reactive received (in quadrant 3 and 4)	kvarh	
Reactive delivered (in quadrant 1 and 2)	kvarh	
Reactive total (delivered + received)	kvarh	
Reactive net (delivered – received)	kvarh	
<b>Frequency Metering</b>		
	Hz	PXR 20 and PXR 25: Not available PXR 35: ±0.1 Hz
<b>Power Factor Metering</b>		
	N/A	PXR 35: Available PXR 20 and 25: Not available

① Neutral current accuracy for internal sensor (four-pole) breakers.

② From 50 A to 125 A, the current accuracy is ± 0.50% of reading and the power and energy metering is ±1% of reading; below 50 A, the accuracy is ±1% of reading and the power and energy metering is ±2% of reading.

③ The PXR 35 includes voltage metering for line and load. By default, the line side is VDB1 (upper terminals) and has 0.25% accuracy. The accuracy for VDB2 (lower terminals) is 1%.

**Note:** Maximum and minimum values are held until reset using PXPMP or the display. Demand values are on a configurable fixed or sliding window of 5 to 60 minutes. The power and energy metering and the protection functions are calculated with the convention that power flow is from line to load through the circuit breaker. This assumes the top side conductor to be the line side. If the distribution system is configured such that the bottom side is the line side, the power values will indicate reverse power. This can be changed by using the display and navigation button. Navigate to the Edit Settings menu and under Power Feed, select Forward or Reverse.

**Table 20.7-6. Magnum PXR Switchgear Class UL 1066 Low-Voltage Power Circuit Breakers**

Frame Amperes	Breaker Type	Frame Type	rms Symmetrical Current Ratings kA 50/60 Hz ①			Short-Time Withstand Rating	Available Programmed Nominal (I <sub>n</sub> ) Rating for PXR Trip Units
			Interrupting at 254Vac	Interrupting at 508Vac	Interrupting at 635Vac		
800	MPN-408	Narrow	42	42	42	42	100 ②, 200, 250, 300, 400, 600, 800
	MPN-608	Narrow	65	65	65	65	
	MPN-C08	Narrow	100	100	100	65	
	MPS-408	Standard	42	42	42	42	
	MPS-608	Standard	65	65	65	65	
	MPS-808	Standard	85	85	85	85	
1200	MPN-412	Narrow	42	42	42	42	100 ②, 200, 250, 300, 400, 600, 800, 1000, 1200
	MPN-612	Narrow	65	65	65	65	
	MPN-C12	Narrow	100	100	100	100	
	MPS-612	Standard	65	65	65	65	
	MPS-812	Standard	85	85	85	85	
	MPS-C12	Standard	100	100	100	85	
1600	MPN-416	Narrow	42	42	42	42	100 ②, 200, 250, 300, 400, 600, 800, 1000, 1200, 1600
	MPN-616	Narrow	65	65	65	65	
	MPN-C16	Narrow	100	100	100	65	
	MPS-616	Standard	65	65	65	65	
	MPS-816	Standard	85	85	85	85	
	MPS-C16	Standard	100	100	100	85	
2000	MPN-620	Narrow	65	65	65	65	100 ②, 200, 250, 300, 400, 600, 800, 1000, 1200, 1600, 2000
	MPN-C20	Narrow	100	100	100	65	
	MPS-620	Standard	65	65	65	65	
	MPS-820	Standard	85	85	85	85	
	MPS-C20	Standard	100	100	100	85	
	2500	MPS-625	Standard	65	65	65	
MPS-825		Standard	85	85	85	85	
MPS-C25		Standard	100	100	100	85	
3200		MPS-632	Standard	65	65	65	65
	MPS-832	Standard	85	85	85	85	
	MPS-C32	Standard	100	100	100	85	
4000	MPN-640	Double Narrow	65	65	65	65	2000, 2500, 3200, 4000
	MPN-840	Double Narrow	85	85	85	85	
	MPN-C40	Double Narrow	100	100	100	65	
	MPS-840	Double	85	85	85	85	
	MPS-C40	Double	100	100	100	100	
	5000	MPS-850	Double	85	85	85	
MPS-C50		Double	100	100	100	100	
6000	MPS-C60 ③	Double	100	100	100	100	3200, 4000, 5000, 6000

① Interrupting ratings shown based on breaker equipped with integral PXR trip unit. Interruption ratings for non-automatic breakers are equal to the published short-time withstand rating. These interruption ratings are based on the standard duty cycle consisting of an open operation, a 15-second interval and a close-open operation, in succession, with delayed tripping in case of short-delay devices. The standard duty cycle for short-time ratings consists of maintaining the rated current for two periods of 0.5 second each, with a 15-second interval of zero current between the two periods.

② 100 A nominal is only available in narrow frame options.

③ Breaker applied in a tested fan cooled enclosure.

## Metering Devices



Power Xpert Energy Meter (PXE)

### Power Xpert Energy Meter (PXE)

The PXE offers a new level of accessibility to the critical information required to manage electrical distribution systems from anywhere in the world. The meter supports sag/swell waveform capture and provides real-time circuit information in both numeric and graphical formats to help monitor circuit parameters, such as current loading, voltage and power levels, and harmonics. The information can be viewed using the optional web-enabled communication module. Optional WiFi offers users enhanced connectivity and ability to access the web browser to view and configure the meter from anywhere.

Meter features include:

- ANSI C12.20 0.1 Class and IEC 61000-4-30 Class S revenue meter accuracy will help meet stringent customer specifications
- 512 samples per cycle waveform capture
- Fourth CT input to measure neutral current
- Available in 1 A/5 A, and 333 mV CT type inputs
- Optional 7-inch display
- Supports a wide-range of communication protocols with the optional comms module (ModbusTCP/IP, BACnet/IP, EtherNet/IP, IEC 61850, DNP3.0 over IP, MQTT, PROFINET and several others)
- 8 GB storage with up to 1-second interval data logging



PXQ

### PXQ

PXQ utilizes aggregated power quality metrics to put disturbance events into context along with adaptable views and personalization. The PXQ includes on-board web pages, allowing for enhanced root-cause analysis of power quality events.

The PXQ series includes:

- Power quality health index
- Integrated event analysis
- Sequence of events recording
- Demand profile and energy usage comparison
- Multi-channel waveform and graphs



PXQ with PXQ-ENH and Two PXQ-SER

### PXQ Expansion Modules

PXQ provides options for additional capabilities and customization.

#### Enhanced Capture Module (PXQ-ENH)

Improve your PXQ's diagnostic capabilities with the Enhanced Capture Module that can detect and record high-speed voltage transients.

- Detect and record high-speed voltage transients as short as 100 ns with up to 10 kV magnitude
- Forensic waveform data available with 1 cycle (17 ms) COMTRADE at 167,000 samples per cycle
- When combined with the PXQ-ST2-1A1, replaces the PXM8000

#### Expanded Input Module (PXQ-SER)

Each PXQ can have up to two input expansion modules that each have 16 additional digital inputs, providing up to a total of 40 inputs (8 + 16 + 16). The digital inputs can be configured for the following:

- Status monitoring and alerts
- Sequence of events historian
- Pulse counting (WAGES)

Communications

Automatic Transfer



PXG1000

Power Xpert Gateway 1000

Ethernet communications available via Power Xpert Gateway PXG1000 with one of three configurations available in low-voltage switchgear:

Basic (Gateway)

- Applications are limited to setpoint adjustments and third-party application support
- Configured to be similar to the PXG900

Enhanced (Dashboard)

- Configured to provide a collection of views ranging from single-line diagrams to data from devices like meters, relays and trip units
- Can be integrated into the switchgear or remotely mounted
- Requires an HMI to be installed
- Allows for remote enabling of the Arcflash Reduction Maintenance System via communications
- Ability to configure setpoints along with remotely opening and closing of circuit breakers
- Initiate a transfer scheme for uninterrupted power

Enhanced plus Remote Racking

Includes all of the options listed above with the addition to control any integral remote racking (MR2) devices installed in the circuit breakers.



ATC-900

Automatic transfer and intelligent control packages are as follows:

- Eaton ATC-900 controller
  - Automatic transfer for a two source lineup with no tie breaker
  - Additional option for a 7-inch screen available
- Eaton programmable logic controller (PLC) with Eaton touch screen
  - Standardized schemes for Main-Main, Main-Gen, Main-Tie-Main, Main-Tie-Gen and Main-Tie-Tie-Main available
  - Standardized schemes are supported by Eaton PSC for troubleshooting ease in the field
  - Usable with a standard 15-inch Eaton HMI or a PDMC Enhanced platform
- Eaton Power Systems Control (offered through Eaton's Engineering Services & Systems)
  - Custom automatic transfers
  - On-site commissioning
  - Integration into existing networks



Programmable Logic Controller

For information on automatic transfer and intelligent control solutions, see the [LVA Automatic and Intelligent Solutions brochure](#).

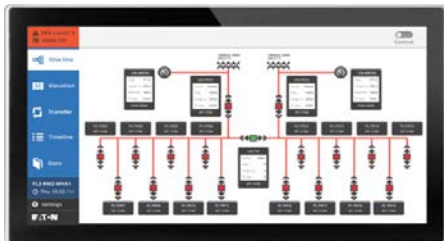

Enhanced Graphics Option  
(Enhanced Configuration)

## High-Resistance Grounding

### General Description

Where continuity of service is a high priority, high-resistance grounding can add the safety of a grounded system while minimizing the risk of service interruptions due to grounds. The concept is a simple one: provide a path for ground current via a resistance that limits the current magnitude, and monitor to determine when an abnormal condition exists.

This provides for maximum continuity of service, because no tripping occurs for the resistance limited ground fault.

The ground current path is provided at the point where the service begins, by placing resistance in the connection from system neutral to ground. Control equipment continuously measures ground current; a relay detects when the current exceeds a predetermined level. An alarm alerts building personnel that a ground exists. The system has built-in fault tracing means to assist in finding the source of the ground. An integral transformer provides control power from the primary source.

### Standard Features (Basic Version)

- Current sensing ground fault detection (1–5 A pickup/0.5–20 second delay)
  - 1–10 A option with 2 A increment
  - custom option available
- Ground current transformer (10/10 ratio)
- Control circuit disconnect switch (fused)
- Lockable door handle
- Ground current ammeter (0–10 A, 1% accuracy)
- Indicating lights:
  - Red (ground fault)
  - Green (normal)
  - White (pulse)
- Adjustable pulsing timer (0–10 seconds)
- Tapped resistors (1–5 A)
- Three-position selector switch (normal, pulse, test)
- Control switch for manual or automatic reset
- Ground fault contacts (1NO/1NC)
- Shorting terminal block for ground current transformer
- UL label
- Rated for use up to 200 kA fault current system
- Front accessible
- Nylon flag type wiremarkers
- Three “zig-zag” or “wye-broken delta” grounding transformers for systems without a neutral point



*Integrated HRG*

### Digital HRG Compartment Features

Standardized digital HRG compartment that condenses the HRG functionality into a 1/4-high arrangement.

- UL and NEC compliant
- Utilizes Bender NGRM500
- Built-in neutral resistor health monitoring
- Compliant to CSA C22.2 No. 295 requirements
- Available in 5 A (1–5 A) or 10 A (1–10 A in 2 A increments) tapped resistors
- Local HMI is provided for programming
- Accessible through the PXG1000 Enhanced option

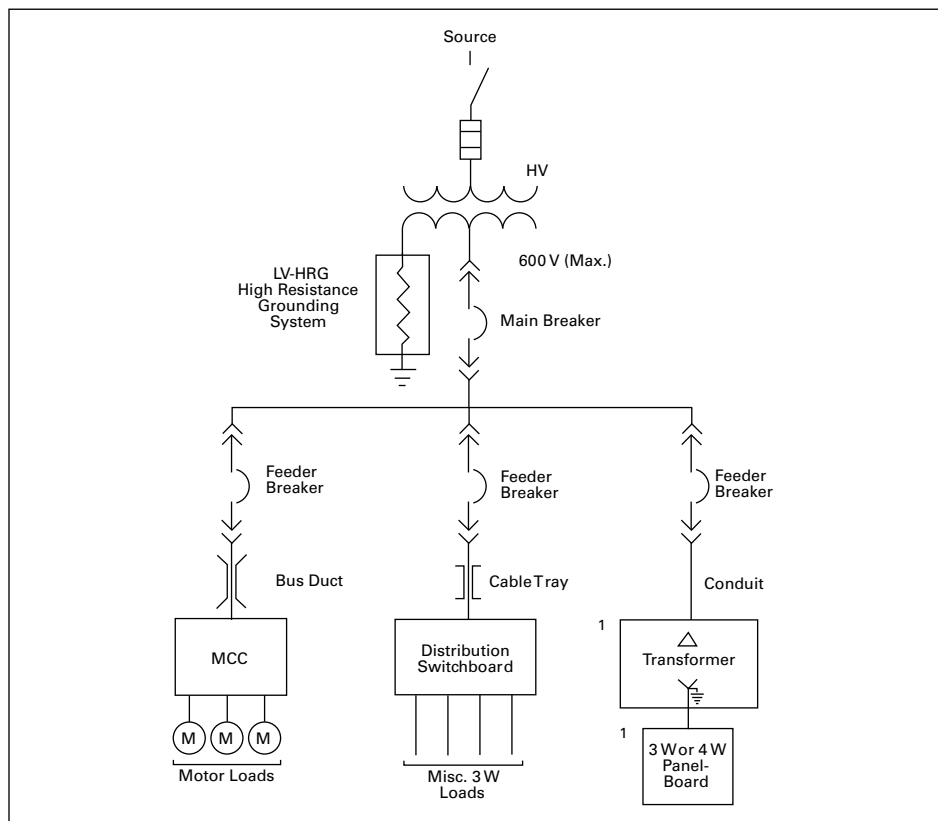

**Figure 20.7-2. Typical Distribution System**

① Phase-to-neutral loads require a delta-wye distribution transformer. The neutral on the secondary side of this transformer must be solidly grounded.

## Surge Protection Devices



### Integrated SPDs

Eaton integrates our industry-leading SPD Series surge protective devices into panelboard and switchboard assemblies. Lead length is kept to a minimum to maximize SPD performance. Integrated SPD units are UL listed and labeled to UL 1449 5th Edition.

Key features include:

- Thermally protected metal oxide varistor (MOV) technology
- 20 kA nominal discharge current ( $I_n$ ) rating (maximum rating assigned by UL)
- 50 through 400 kA surge current capacity ratings
- Three feature package options (basic, standard, and standard with surge counter)
- 200 kA short-circuit current rating (SCCR)
- 10-year warranty

The breadth of the SPD Series' features, options and configurations ensures that the correct unit is available for all electrical applications, including service entrances, distribution switchboards, panelboards and point-of-use applications.

For complete SPD product description, application and ratings, visit [www.eaton.com/spd](http://www.eaton.com/spd).

### Power Xpert SPD

- The Power Xpert SPD is an advanced monitoring display to track and record surge events and remaining protection status on each phase
- Surge events are categorized as low, medium and high in accordance to the IEEE Standard C62.41. These events are logged with time and date stamps
- The RJ45 Ethernet port provides communication between the surge device and the LAN connection, Modbus TCP/IP or BACnet/IP protocols
- Ability to access the remote webpage through Power Xpert Gateway 1000
- Email alarm notifications are available when configured through Power Xpert Gateway 1000



Table 20.7-7. Feature Package Comparison

Feature	Basic	Standard	Standard with Surge Counter	Power Xpert SPD
Surge protection using thermally protected MOV technology	■	■	■	■
Dual-colored protection status indicators for each phase and the neutral-ground protection mode ①	■	■	■	■
Audible alarm with silence button		■	■	■
Form C relay contact		■	■	■
EMI/RFI filtering, providing up to 50 dB of noise attenuation from 10 kHz to 100 MHz		■	■	■
Surge counter with reset			■	■
Tri-colored protection status indicators for each phase and the neutral-ground protection mode ①				■
Percentage protection remaining status				■
RJ45 Ethernet port for LAN connection, ModbusTCP/IP or BACnet/IP				■
UI webpage and programmable settings				■
Time-and-date stamped surge log and surge categorization				■

① Neutral-ground protection mode available in applicable voltage configurations only.

## Breaker Layouts

### Magnum PXR Rear-Accessible Switchgear

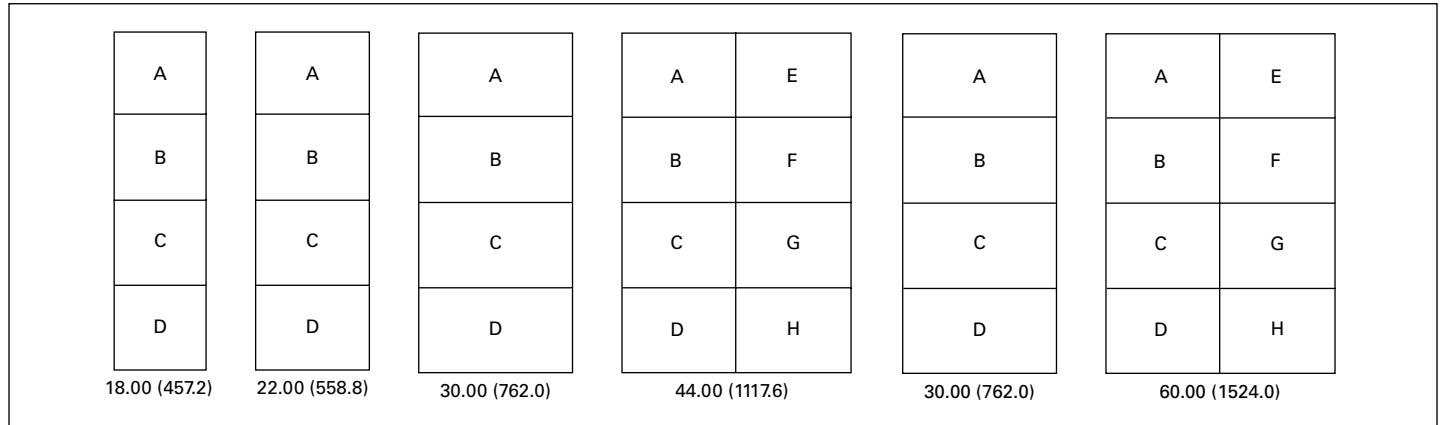

Figure 20.7-3. Breaker Structures—Dimensions in Inches (mm)

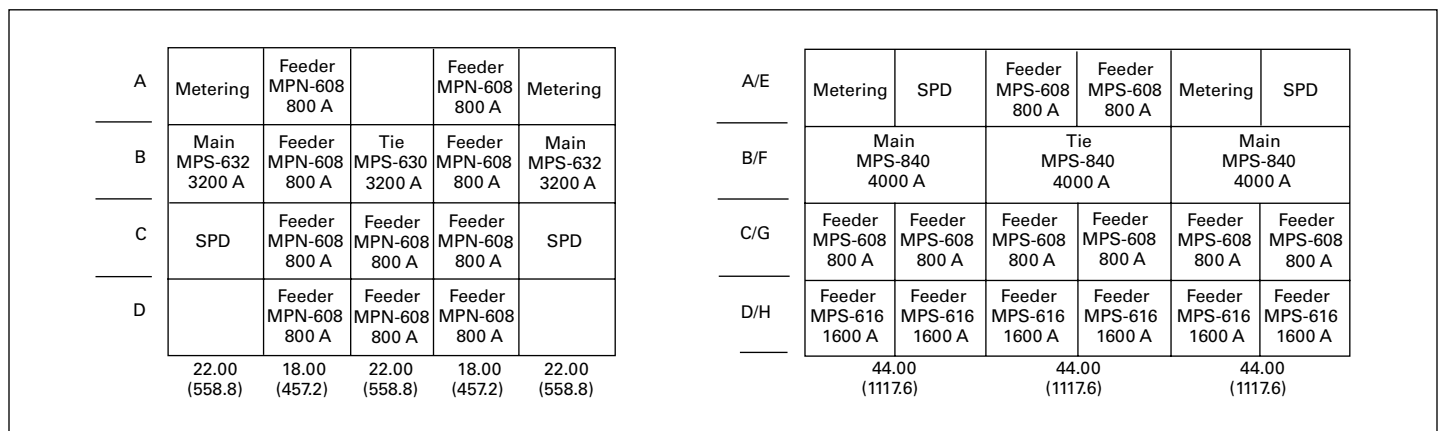

Figure 20.7-4. Main-Tie-Main Example Layouts—Dimensions in Inches (mm)

**Note:** Breaker and cell utilization should keep load amperes below rating of a main breaker due to vertical bus limitations. Cable used in the conduit areas are limited to 75 °C ampacity values per the NEC for ampacity calculations. Any cell not used as a feeder breaker may be a blank, or a feeder breaker provision for future breakers, or SPD surge. Section bus sized per main bus rating (maximum) or by IEEE C37.20.1.

**Note:** Any breaker utilizing an MR2 will need one of the following: main metering compartment, instrument compartment or a transfer scheme compartment in the A-cell in the same structure as the breaker. As a result, a structure with four feeders with MR2 is not possible and will be limited to only three feeders per structure.

**Note:** For breakers utilizing the MR2 and utilizing the remote pendant, there are some instances where the open/close functionality could be locked from either Kirk Keys or the PLC managing the transfer scheme. See engineering drawings for details.

A	Feeder MPS-608 800A	Metering	Transfer	Comms Compt	Metering	Feeder MPS-608 800A
B	Feeder MPS-608 800A	Main MPS-632 3200A	Tie MPS-632 3200A	Tie MPS-632 3200A	Main MPS-632 3200A	Feeder MPS-608 800A
C	Feeder MPS-608 800A					Feeder MPS-608 800A
D	Feeder MPS-608 800A					Feeder MPS-608 800A
	22.00 (558.0)	22.00 (558.0)	22.00 (558.0)	22.00 (558.0)	22.00 (558.0)	22.00 (558.0)

A/E	Metering		Feeder MPS-608 800A	Transfer	Comms Compt	Feeder MPS-608 800A	Metering	
B/F	Main MPS-850 5000A		Feeder MPS-608 800A	Tie MPS-850 5000A	Tie MPS-850 5000A	Feeder MPS-608 800A	Main MPS-850 5000A	
C/G			Feeder MPS-608 800A			Feeder MPS-608 800A		
D/H			Feeder MPS-608 800A			Feeder MPS-608 800A		
	44.00 (1117.6)		22.00 (558.0)	44.00 (1117.6)	44.00 (1117.6)	22.00 (558.0)	44.00 (1117.6)	

Figure 20.7-5. Main-Tie-Tie-Main Example Layouts—Dimensions in Inches (mm)

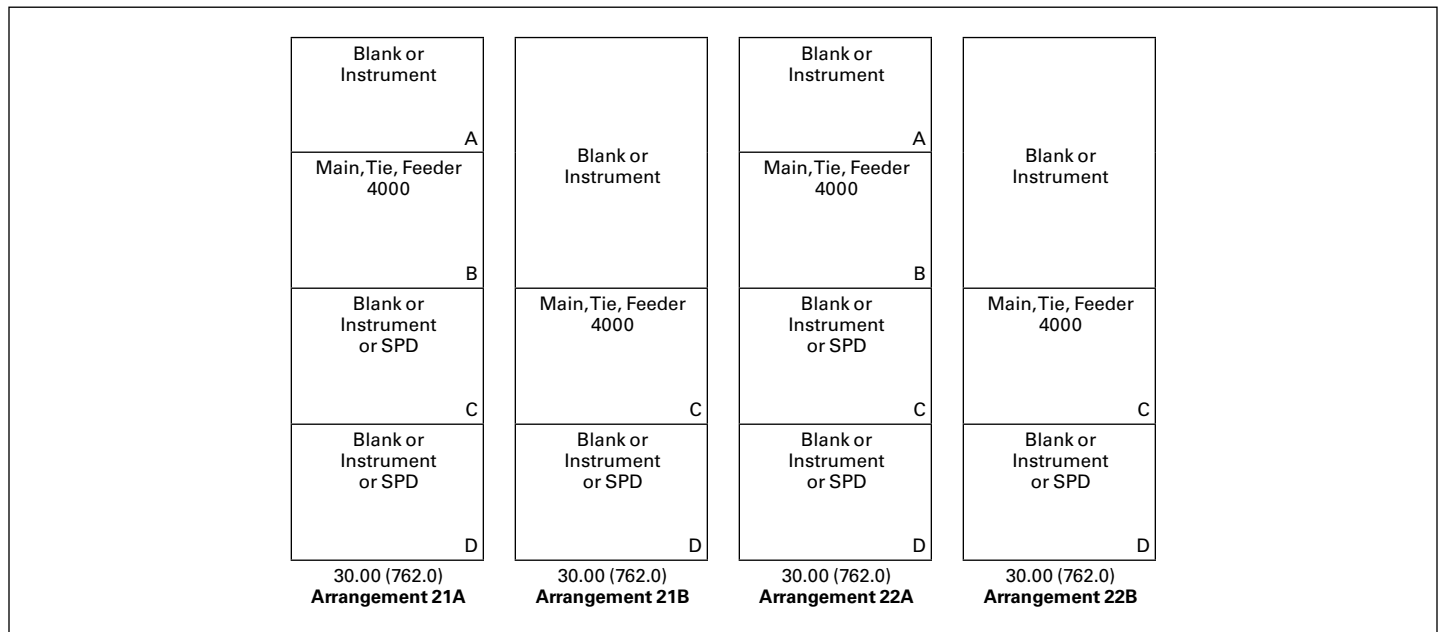
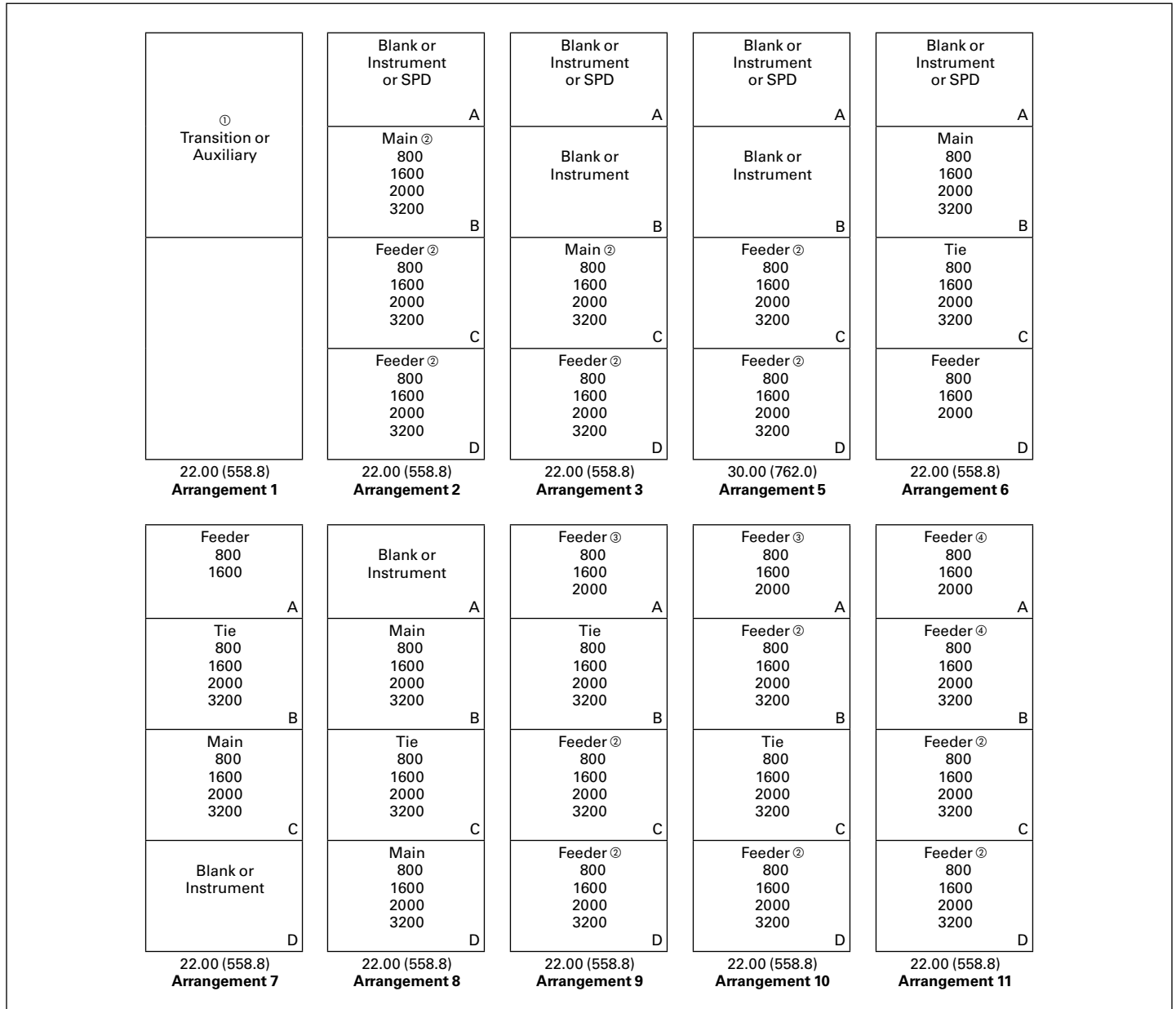

Figure 20.7-6. Typical Structure and Breaker Arrangements—4000 A, MPN Mains, Ties, Feeders and Miscellaneous—Dimensions in Inches (mm)  
 Note: Minimum structure depth is 72 inches (1829 mm).



**Figure 20.7-7. Typical Structure and Breaker Arrangements—Magnum PXR Mains, Ties, Feeders and Miscellaneous, 3200 A and Below—Dimensions in Inches (mm) ⑤**

- ① A transition section is required when close-coupling to an Eaton sourced liquid filled transformer. A transition section is required when close coupling to non-Eaton sourced transformers. A transition section is required when close coupling to other distribution equipment.
- ② A maximum of two 3200 A breakers are permitted per 22.00-inch (558.8 mm) width of switchgear, one of which must be a main or tie. For a 3200 A frame breaker mounted in the same enclosure with a 4000 A or 5000 A main or tie, contact Eaton.
- ③ Contact Eaton for placement of 2000 A frame breaker in this compartment.
- ④ A maximum of three 2000 A breakers are permitted per 22.00-inch (558.8 mm) width of switchgear. If three are required, positions B, C and D must be used.
- ⑤ Any 22.00-inch (558.8 mm) wide compartment can be a blank or instrument compartment.

**Note:** Breaker and cell utilization should keep load amperes below rating of a main breaker due to vertical bus limitations. Cable used in the conduit areas are limited to 75 °C ampacity values per the NEC for ampacity calculations. Any cell not used as a feeder breaker may be a blank, or a feeder breaker provision for future breakers, or SPD surge. Section bus sized per main bus rating (maximum) or by IEEE C37.20.1.

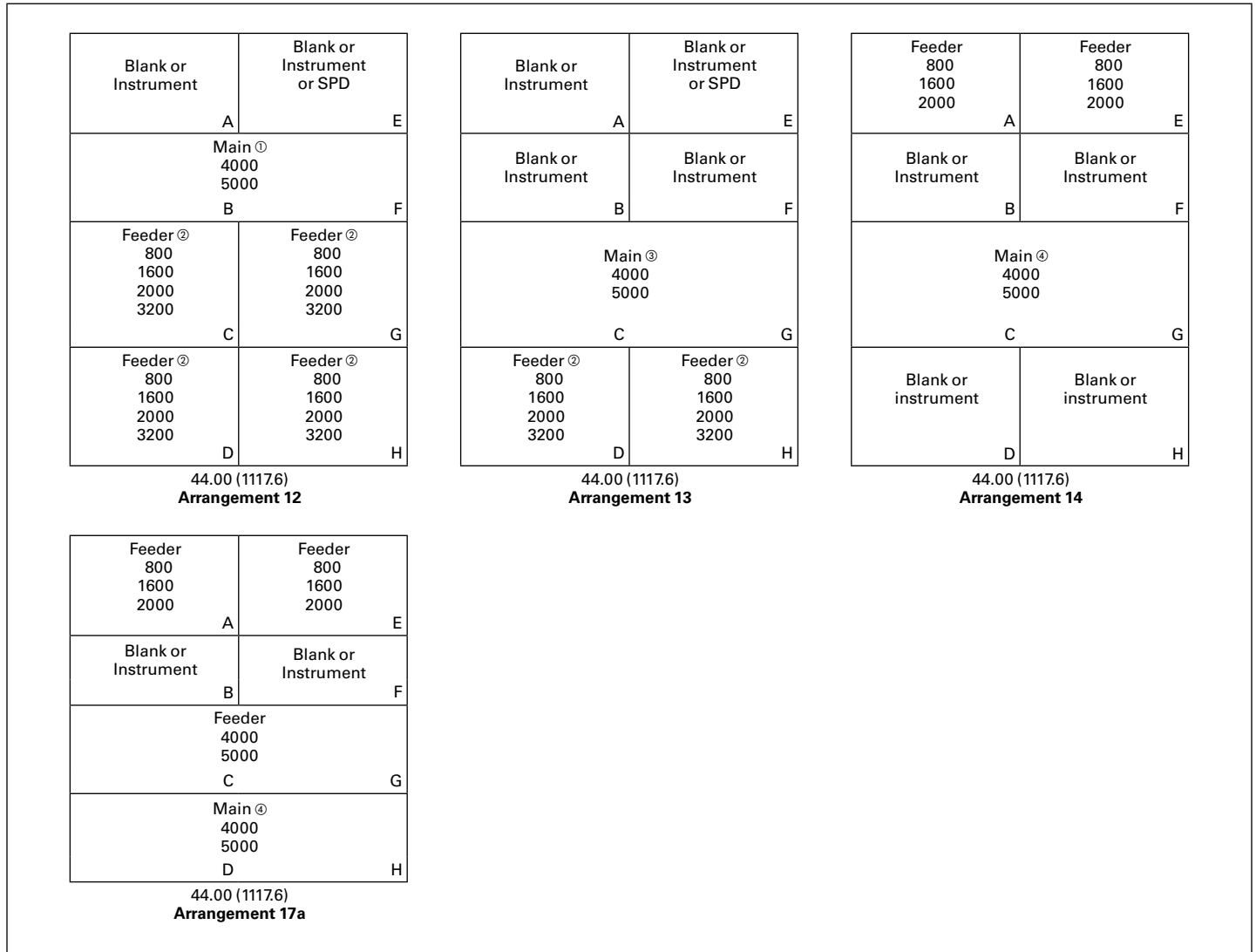
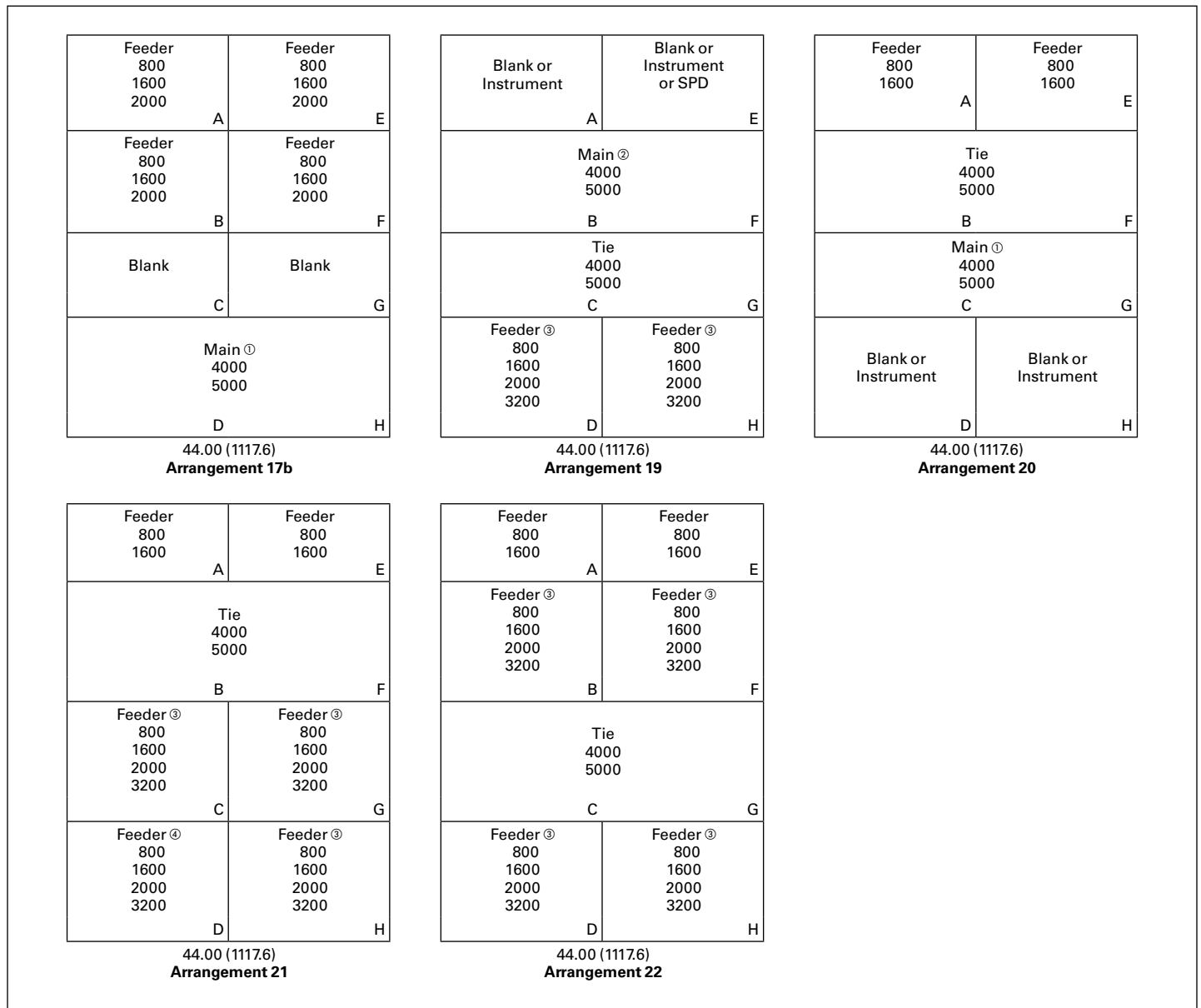

Figure 20.7-8. Typical Structure and Breaker Arrangements—Magnum PXR Mains, 4000 A and 5000 A—Dimensions in Inches (mm) ⑤

- ① If you have four-wire service and service entrance requirement, busway connection or cable connection, the bus or cables must enter from the top.
- ② A maximum of two 3200 A breakers are permitted per 22.00-inch (558.8 mm) width of switchgear, one of which must be a main or tie. For a 3200 A frame breaker mounted in the same enclosure with a 4000 A or 5000 A main or tie, contact Eaton.
- ③ Service entrance option is not available with feeder breakers mounted in this structure.
- ④ If you have four-wire service and service entrance requirement, busway connection or cable connection, the bus or cables must enter from the bottom.
- ⑤ Any 22.00-inch (558.8 mm) wide compartment can be a blank or instrument compartment with the following exception: A 44.00-inch (1117.6 mm) wide instrument compartment must be adjacent to another 44.00-inch (1117.6 mm) wide compartment in the structure.

**Note:** Breaker and cell utilization should keep load amperes below rating of a main breaker due to vertical bus limitations. Cable used in the conduit areas are limited to 75 °C ampacity values per the NEC for ampacity calculations. Any cell not used as a feeder breaker may be a blank, or a feeder breaker provision for future breakers, or SPD surge. Section bus sized per main bus rating (maximum) or by IEEE C37.20.1.



**Figure 20.7-9. Typical Structure and Breaker Arrangements—Magnum PXR Mains and Ties, 4000 A and 5000 A—Dimensions in Inches (mm) ④**

- ① If you have four-wire service and service entrance requirement, busway connection or cable connection, the bus or cables must enter from the bottom.
- ② If you have four-wire service and service entrance requirement, busway connection or cable connection, the bus or cables must enter from the top.
- ③ A maximum of two 3200 A breakers are permitted per 22.00-inch (558.8 mm) width of switchgear, one of which must be a main or tie. For a 3200 A frame breaker mounted in the same enclosure with a 4000 A or 5000 A main or tie, contact Eaton.
- ④ Any 22.00-inch (558.8 mm) wide compartment can be a blank or instrument compartment with the following exception: A 44.00-inch (1117.6 mm) wide instrument compartment must be adjacent to another 44.00-inch (1117.6 mm) wide compartment in the structure.

**Note:** Breaker and cell utilization should keep load amperes below rating of a main breaker due to vertical bus limitations. Cable used in the conduit areas are limited to 75 °C ampacity values per the NEC for ampacity calculations. Any cell not used as a feeder breaker may be a blank, or a feeder breaker provision for future breakers, or SPD surge. Section bus sized per main bus rating (maximum) or by IEEE C37.20.1.

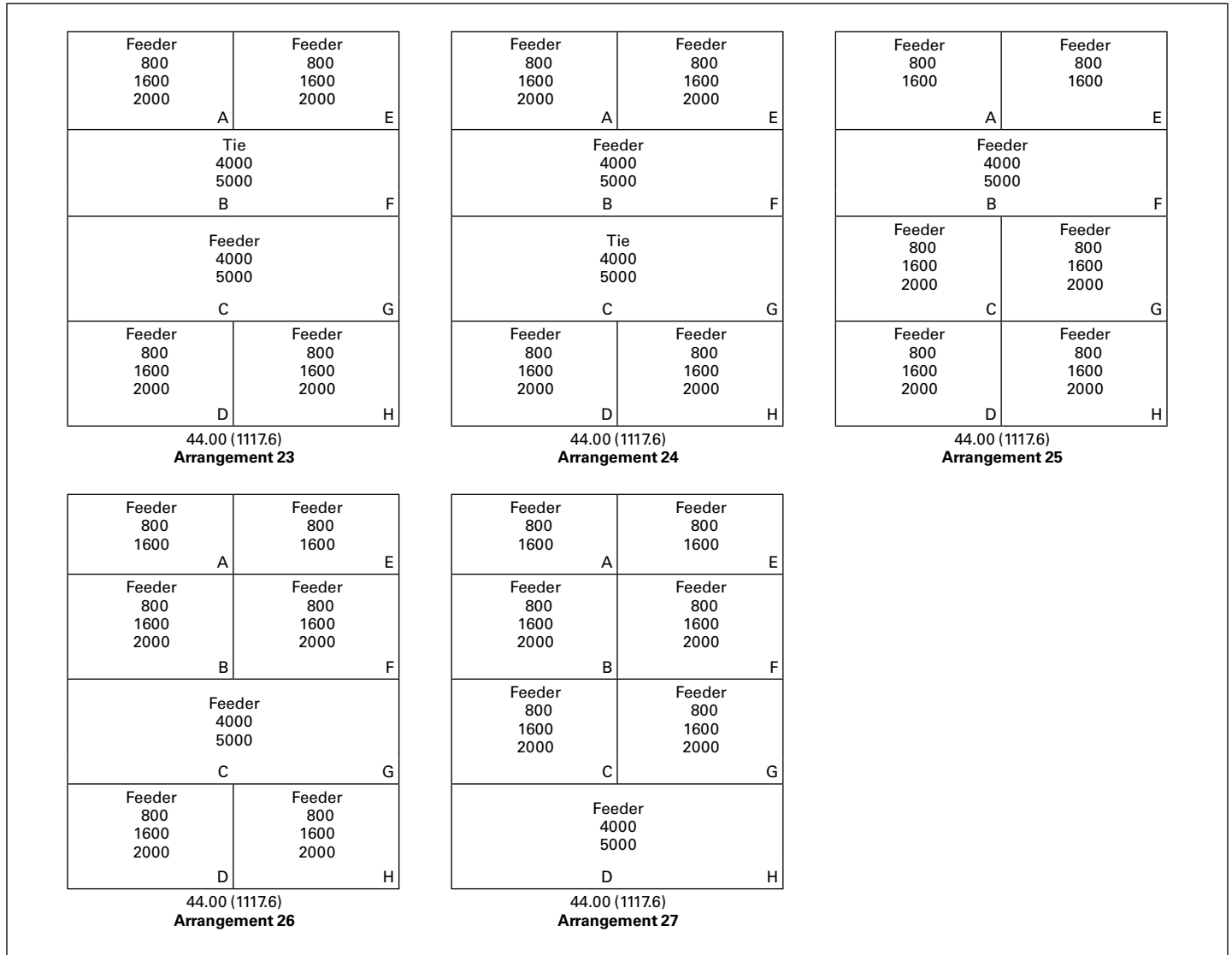

Figure 20.7-10. Typical Structure and Breaker Arrangements—Magnum PXR Ties and Feeders, 4000 A and 5000 A—Dimensions in Inches (mm)

**Note:** Any 22.00-inch (558.8 mm) wide compartment can be a blank or instrument compartment with the following exception: A 44.00-inch (1117.6 mm) wide instrument compartment must be adjacent to another 44.00-inch (1117.6 mm) wide compartment in the structure.

**Note:** Breaker and cell utilization should keep load amperes below rating of a main breaker due to vertical bus limitations. Cable used in the conduit areas are limited to 75 °C ampacity values per the NEC for ampacity calculations. Any cell not used as a feeder breaker may be a blank, or a feeder breaker provision for future breakers, or SPD surge. Section bus sized per main bus rating (maximum) or by IEEE C37.20.1.

Magnum PXR Rear-Accessible Switchgear

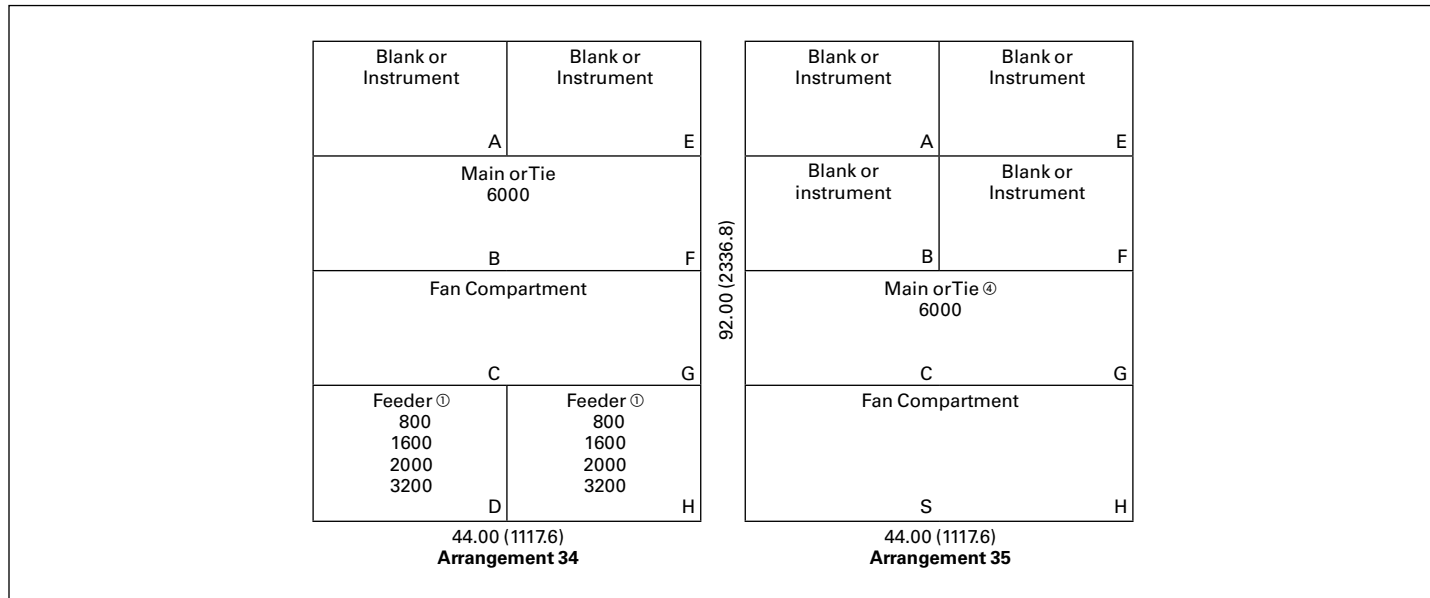
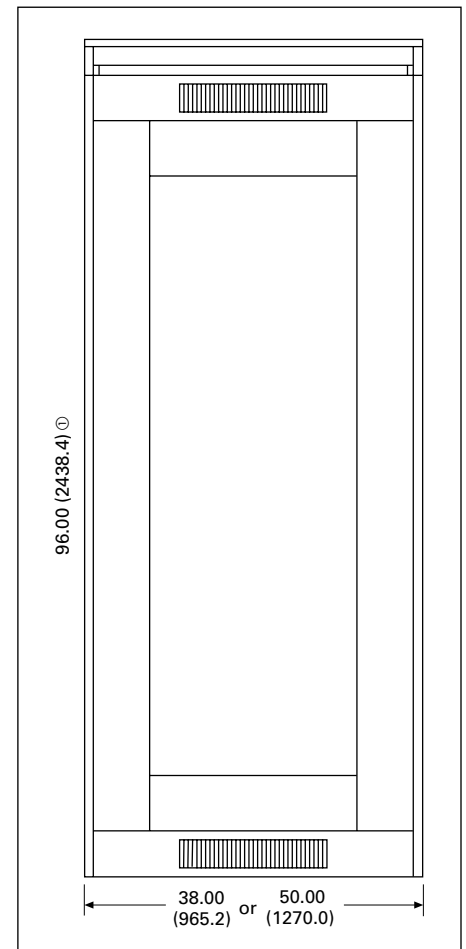
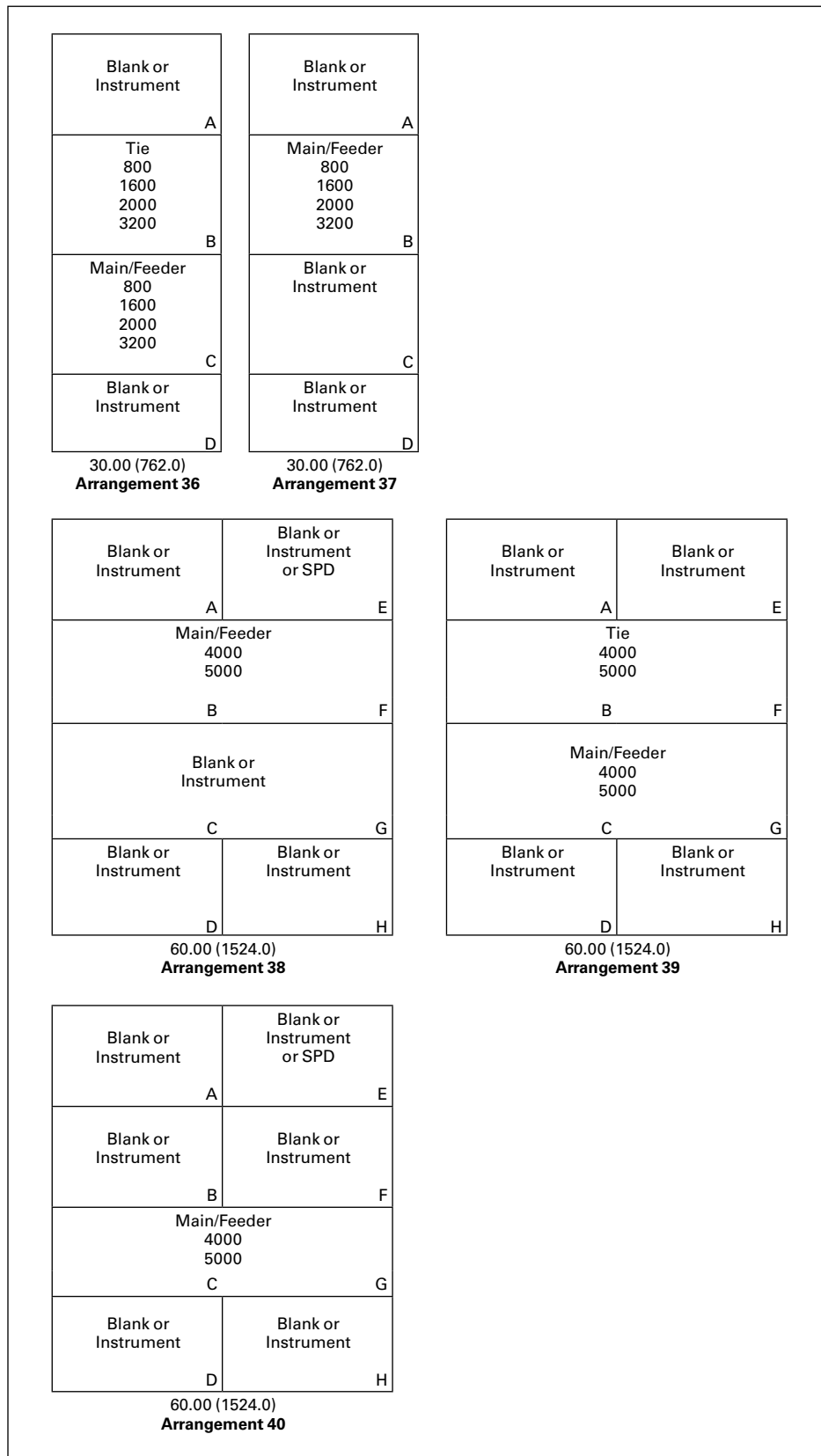

Figure 20.7-11. Typical Structure and Breaker Arrangements—Magnum PXR Mains and Ties, 6000 A—Dimensions in Inches (mm) ③

- ① A maximum of two 3200 A breakers are permitted per 22.00-inch (559 mm) width of switchgear, one of which must be a main or tie. For a 3200 A frame breaker mounted in the same enclosure with a 4000 A, 5000 A or 6000 A main or tie, contact Eaton.
- ② When a top-of-gear breaker lifter is used, height is 99.00 inches (2514.6 mm) total.
- ③ Any 22.00-inch (558.8 mm) wide compartment can be a blank or instrument compartment with the following exception: 44.00-inch (1117.6 mm) wide instrument compartment must be adjacent to another 44.00-inch (1117.6 mm) wide compartment in the structure.
- ④ May need a 44.00-inch (1117.6 mm) wide section on both sides of the tie for layout to be correct.

**Note:** Breaker and cell utilization should keep load amperes below rating of a main breaker due to vertical bus limitations. Cable used in the conduit areas are limited to 75 °C ampacity values per the NEC for ampacity calculations. Any cell not used as a feeder breaker may be a blank, or a feeder breaker provision for future breakers, or SPD surge. Section bus sized per main bus rating (maximum) or by IEEE C37.20.1.



**Figure 20.7-13. Integrated Group-Mounted Molded Case Circuit Breaker Switchboard**

① When a top-of-gear breaker lifter is used, height is 99.00 inches (2514.6 mm) total.

**Note:** Structures using molded case breakers for distribution will be UL 891 rated with 30-cycle bus bracing.

**Figure 20.7-12. Typical Structure and Breaker Arrangements—Magnum PXR 4-Pole Breakers—Dimensions in Inches (mm)**

Structure Dimensions

Conduit Area Location

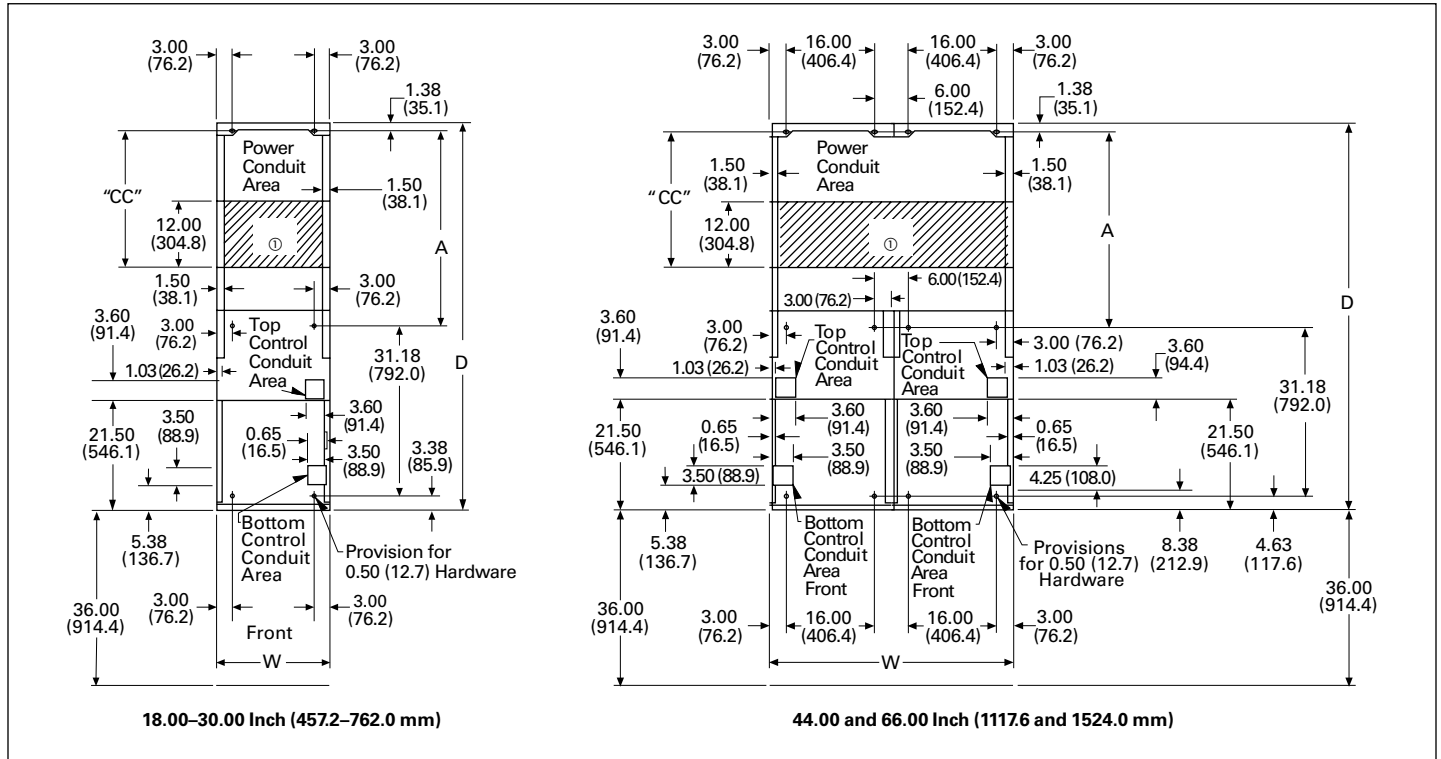

Figure 20.7-14. Floor Plans and Available Conduit Space—18.00, 22.00, 30.00, 44.00, 60.00 Inch (457.2, 558.8, 762.0, 1117.6, 1524.0 mm) Wide Rear-Access Structures—Dimensions in Inches (mm)

① This dimension is reduced by 12.00 inches (304.8 mm) when vertical section is close coupled to a dry-type transformer due to secondary bus connections.

Note: See Table 20.7-8 for further information on cable and conduit recommendations.

**Table 20.7-8. Rear-Access Structure Dimensions in Inches (mm)**

W	D	A	CC	Recommended Number of Conduits
				4.00 Inch (101.6 mm)
18.00 (457.2)	54.00 (1371.6)	18.00 (457.2)	7.30 (185.4)	2
	60.00 (1524.0)	24.00 (609.6)	13.30 (337.8)	4
	66.00 (1676.4)	30.00 (762.0)	19.30 (490.2)	6
	72.00 (1828.8)	36.00 (914.4)	25.30 (642.6)	8
	78.00 (1981.2)	42.00 (1066.8)	31.30 (795.0)	10
	84.00 (2133.6)	48.00 (1219.2)	37.30 (947.4)	12
	90.00 (2286.0)	54.00 (1371.6)	43.30 (1099.8)	16
22.00 (558.8)	54.00 (1371.6)	18.00 (457.2)	7.30 (185.4)	3
	60.00 (1524.0)	24.00 (609.6)	13.30 (337.8)	6
	66.00 (1676.4)	30.00 (762.0)	19.30 (490.2)	9
	72.00 (1828.8)	36.00 (914.4)	25.30 (642.6)	12
	78.00 (1981.2)	42.00 (1066.8)	31.30 (795.0)	15
	84.00 (2133.6)	48.00 (1219.2)	37.30 (947.4)	18
	90.00 (2286.0)	54.00 (1371.6)	43.30 (1099.8)	21
24.00 (609.6)	60.00 (1524.0)	24.00 (609.6)	9.08 (230.6)	5
	66.00 (1676.4)	30.00 (762.0)	15.08 (383.0)	8
	72.00 (1828.8)	36.00 (914.4)	21.08 (535.4)	12
	78.00 (1981.2)	42.00 (1066.8)	27.08 (687.8)	15
	84.00 (2133.6)	48.00 (1219.2)	33.08 (840.2)	18
	90.00 (2286.0)	54.00 (1371.6)	39.08 (992.6)	21
	30.00 (762.0)	54.00 (1371.6)	18.00 (457.2)	7.30 (185.4)
60.00 (1524.0)		24.00 (609.6)	13.30 (337.8)	8
66.00 (1676.4)		30.00 (762.0)	19.30 (490.2)	12
72.00 (1828.8)		36.00 (914.4)	25.30 (642.6)	16
78.00 (1981.2)		42.00 (1066.8)	31.30 (795.0)	20
84.00 (2133.6)		48.00 (1219.2)	37.30 (947.4)	24
90.00 (2286.0)		54.00 (1371.6)	43.30 (1099.8)	28
44.00 (1117.6)	54.00 (1371.6)	18.00 (457.2)	7.30 (185.4)	7
	60.00 (1524.0)	24.00 (609.6)	13.30 (337.8)	14
	66.00 (1676.4)	30.00 (762.0)	19.30 (490.2)	21
	72.00 (1828.8)	36.00 (914.4)	25.30 (642.6)	28
	78.00 (1981.2)	42.00 (1066.8)	31.30 (795.0)	35
	84.00 (2133.6)	48.00 (1219.2)	37.30 (947.4)	42
	90.00 (2286.0)	54.00 (1371.6)	43.30 (1099.8)	49
60.00 (1524.0)	54.00 (1371.6)	18.00 (457.2)	7.30 (185.4)	8
	60.00 (1524.0)	24.00 (609.6)	13.30 (337.8)	16
	66.00 (1676.4)	30.00 (762.0)	19.30 (490.2)	24
	72.00 (1828.8)	36.00 (914.4)	25.30 (642.6)	32
	78.00 (1981.2)	42.00 (1066.8)	31.30 (795.0)	40
	84.00 (2133.6)	48.00 (1219.2)	37.30 (947.4)	48
	90.00 (2286.0)	54.00 (1371.6)	43.30 (1099.8)	56

Section Views

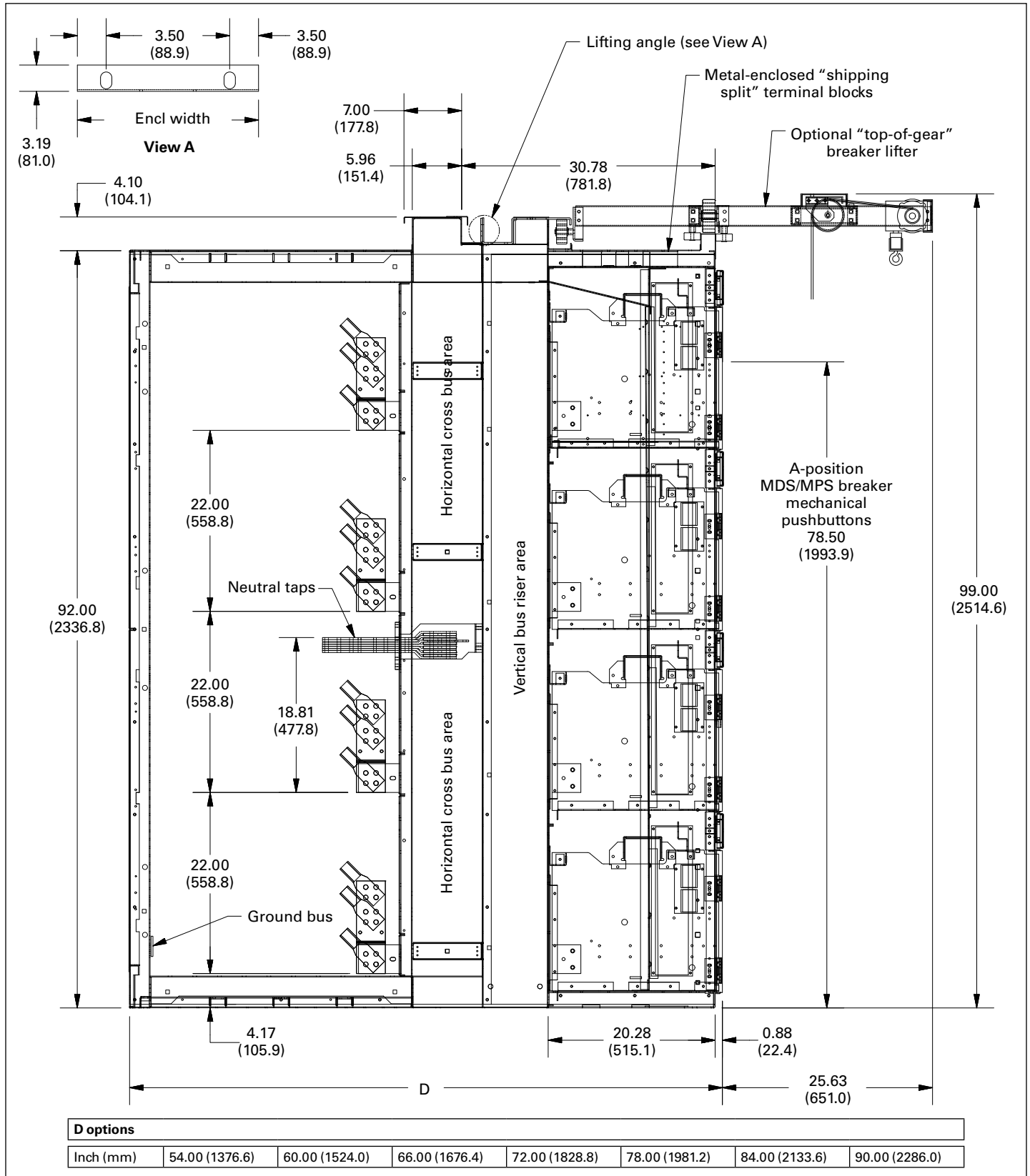

Figure 20.7-15. Section View of a Typical Structure with Magnum Circuit Breakers with Power Xpert Release Trip Units

Outdoor Walk-in Switchgear

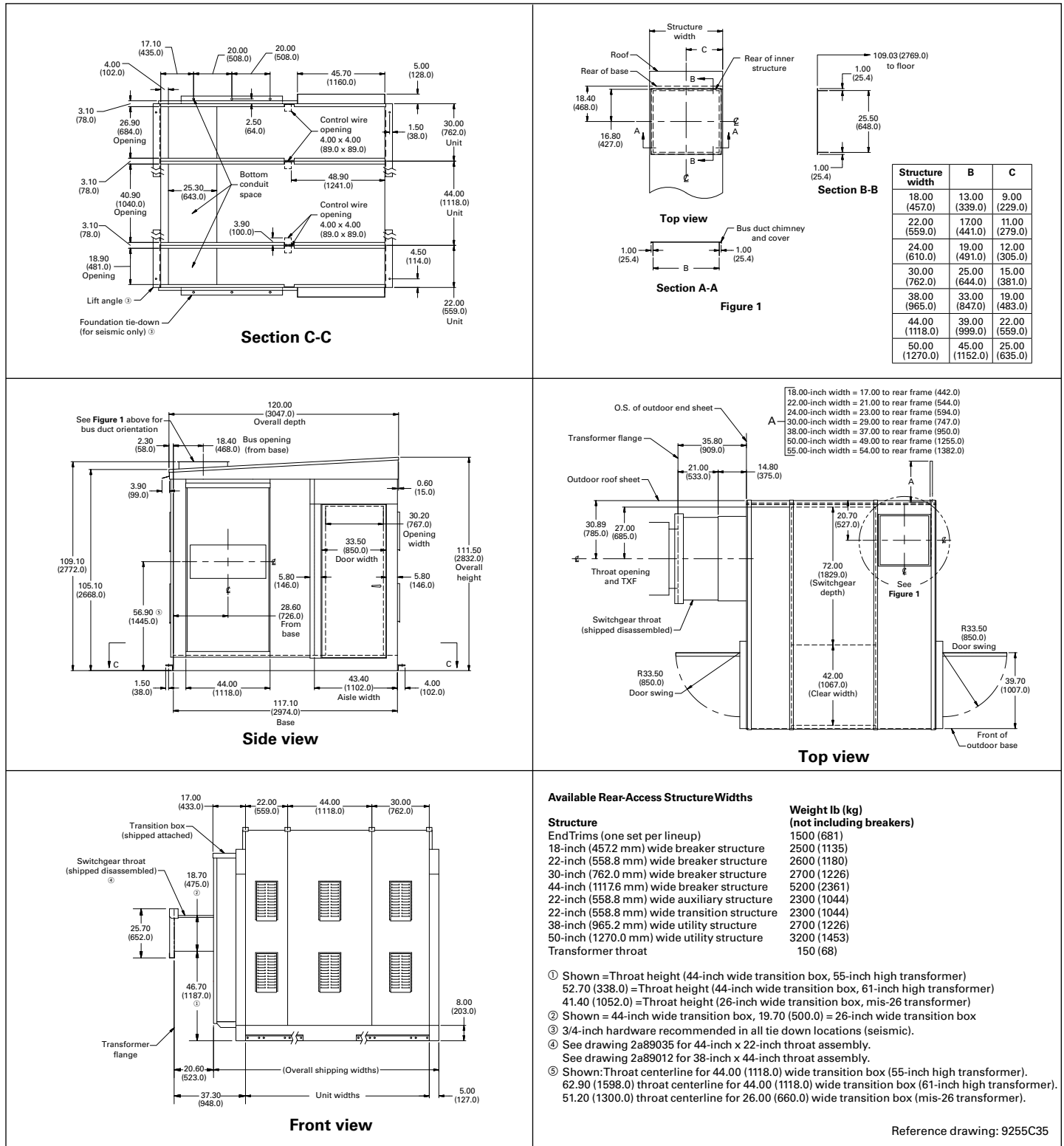

Figure 20.7-16. Outdoor Walk-in Enclosure—Dimensions in Inches (mm)

A	B	C	Centerline of copper connection from bottom of structure
41.38 (1051.1)	51.23 (1301.2)	19.70 (500.4)	55.00 (1397.0)
46.63 (1184.4)	57.00 (1447.8)	18.70 (203.2)	55.00 (1397.0)
52.63 (1336.8)	63.00 (1600.2)	18.70 (203.2)	61.00 (1549.4)

Outdoor Non-Walk-in Switchgear

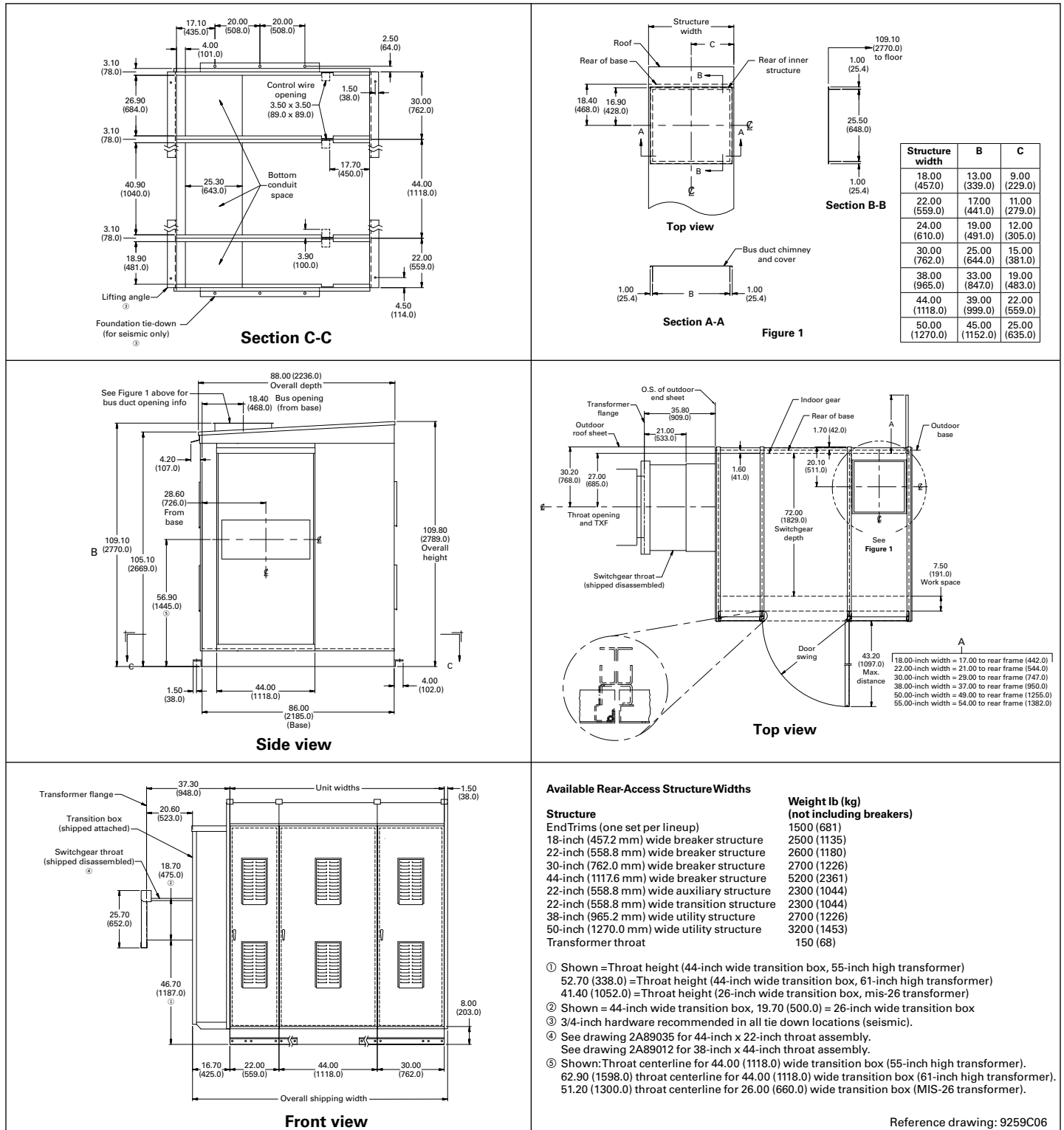

Figure 20.7-17. Outdoor Non-Walk-in Enclosure—Dimensions in Inches (mm)

A	B	C	Centerline of copper connection from bottom of structure
41.38 (1051.1)	51.23 (1301.2)	19.70 (500.4)	55.00 (1397.0)
46.63 (1184.4)	57.00 (1447.8)	18.70 (203.2)	55.00 (1397.0)
52.63 (1336.8)	63.00 (1600.2)	18.70 (203.2)	61.00 (1549.4)

Document References

Instruction manual IB0191006EN for Eaton’s Magnum PXR front- and rear-access low-voltage switchgear.

Typical Breaker Schematics

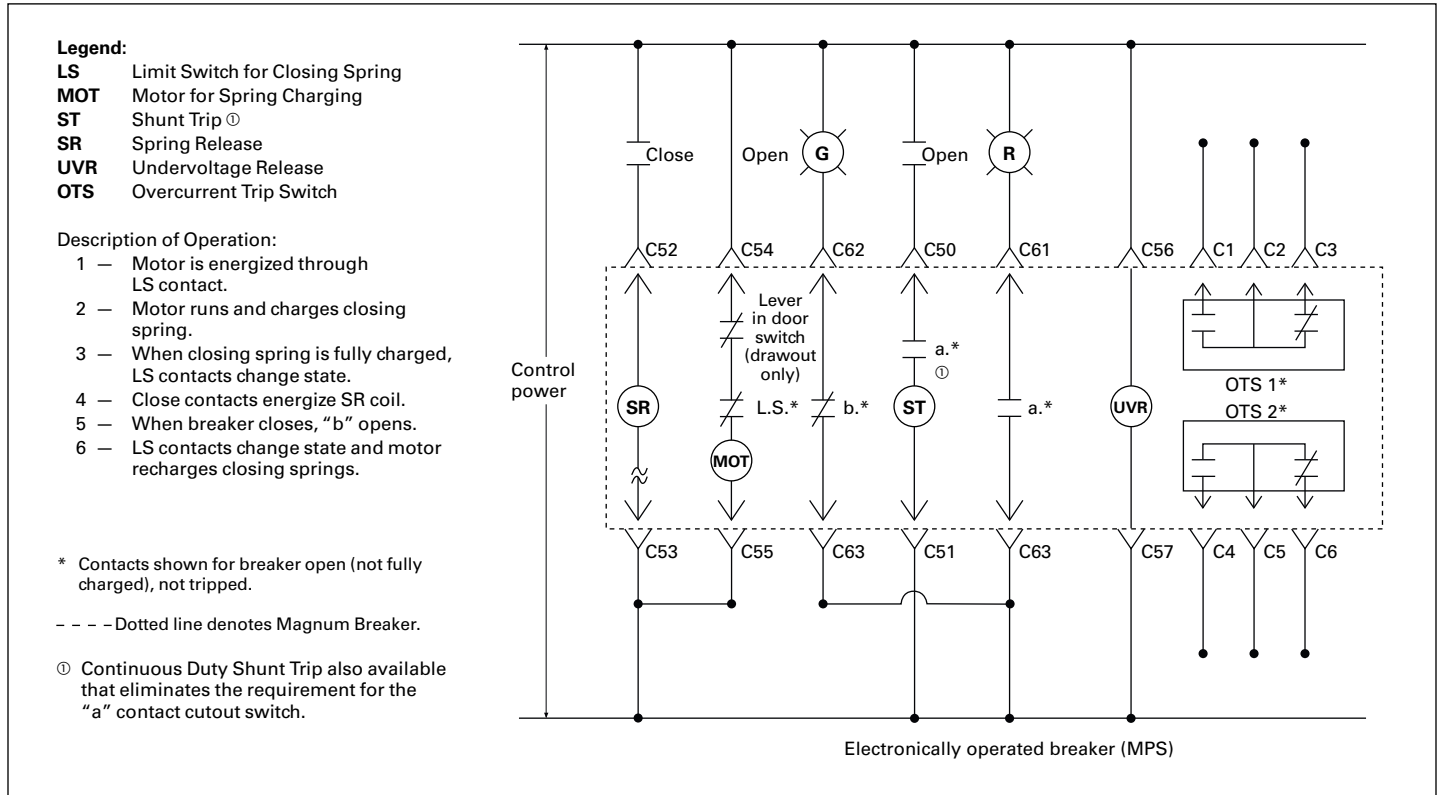

Figure 20.7-18. Typical Magnum PXR Breaker Control Circuit Diagram

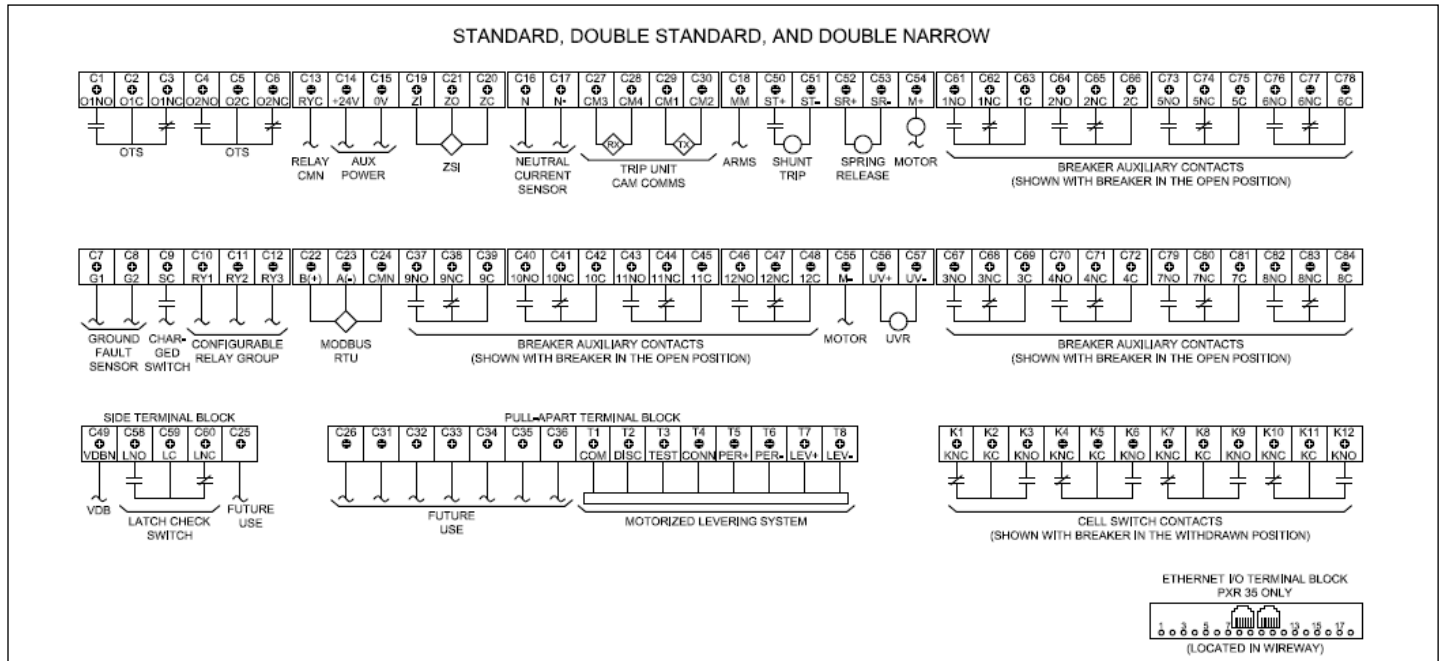

Figure 20.7-19. Typical Standard Frame Magnum PXR Secondary Terminal Block Connection Diagram

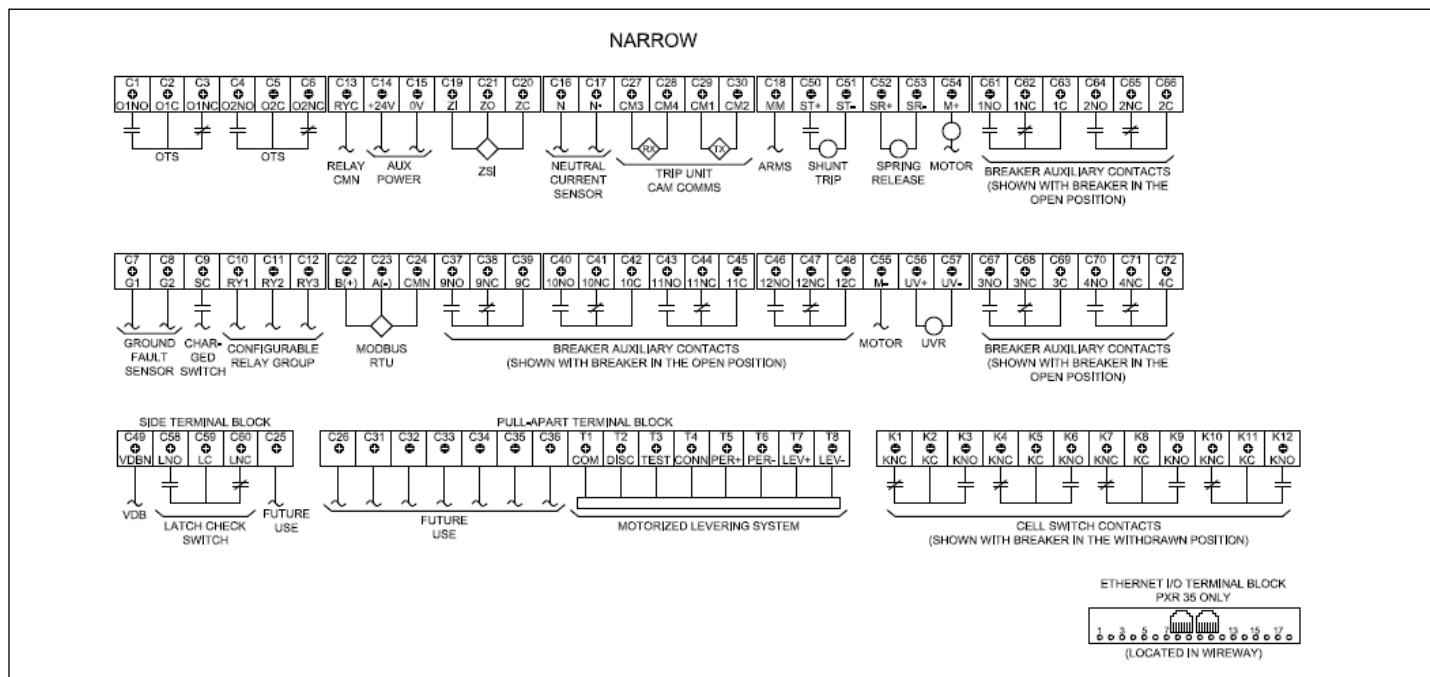

Figure 20.7-20. Magnum PXR Secondary Layout for Narrow Frame

**Heat Loss**

**Table 20.7-9. Heat Loss Data** ①  
**Estimated Heat Loss Per Breaker (Watts)**

Breaker Frame	Drawout Mounting Only
800	150
1600	329
2000	374
3200	719
4000	749
5000	1000
6000	1440

**Estimated Heat Loss Per Structure (Watts)** ①

Loss is based on fully loaded vertical and cross bus rating in a structure as given below.

Rating	Vertical Bus	Cross Bus
2000	410	288
3200	1623	1163
4000	1097	1169
5000	1410	886
6000	2030	1265
8000	—	2240
10,000	—	3500

① For lower than maximum load currents, watt loss may be estimated by reducing the full load loss by the following:

$$W_L = (I_L/I_{FL})^2 W_{FL}$$

Where:

$W_L$  = Load Watts

$W_{FL}$  = Full Load Watts

$I_L$  = Actual Load Current

$I_{FL}$  = Full Load Current

Vertical section bus is sized per main cross bus maximum rating or by IEEE C37.20.1 to a maximum of 5000 A. (4000 A in 18.00-inch [457.2 mm] structure.)

**Note:** In addition to the available bus bracings shown in **Table 20.7-2**, the bus has been tested for short-circuit values of 85 kA for a full 60 cycles.

**Closing Times of Magnum PXR Breakers**

- 5 cycles or less

**Opening Times—Dependent on Function Used**

- Standard instantaneous: 60 ms maximum
- ARMS trip: 40 ms maximum
- Shunt trip: 50 ms maximum
- Trip signal from an Eaton Arc Flash Relay: ~67 ms

**Center of Gravity**

For seismic calculations, the following dimensions should be used to locate the center of gravity for indoor Magnum PXR switchgear.

**Table 20.7-10. Center of Gravity Location**

Dimensions in Inches (mm)		
Vertical	Left-to-Right	From the Front
60.00 (1524.0)	Center of lineup	26.00 (660.4)

**Weights**

**Table 20.7-11. Magnum PXR Indoor Rear Switchgear Structure Approximate Weights (Standard Construction Less Breakers)** ①

Width in Inches (mm)	Depth in Inches (mm)	Approximate Weight in lb (kg)
<b>Breaker Structure</b>		
18.00, 22.00 and 24.00 (457.2, 558.8 and 609.6)	60.00 (1542.0)	1250 (568)
	66.00 (1676.4)	1300 (591)
	72.00 (1828.8)	1350 (614)
	78.00 (1981.2)	1400 (639)
30.00 (762.0)	84.00 (2133.6)	1450 (659)
	90.00 (2286.0)	1500 (682)
	60.00 (1542.0)	1900 (864)
	66.00 (1676.4)	2000 (909)
44.00 (117.6)	72.00 (1828.8)	2100 (955)
	78.00 (1981.2)	2200 (1000)
	84.00 (2133.6)	2300 (1045)
	90.00 (2286.0)	2400 (1091)
60.00 (1524.0)	60.00 (1542.0)	2500 (1136)
	66.00 (1676.4)	2600 (1182)
	72.00 (1828.8)	2700 (1227)
	78.00 (1981.2)	2800 (1273)
60.00 (1524.0)	84.00 (2133.6)	2900 (1318)
	90.00 (2286.0)	3000 (1364)
	60.00 (1542.0)	3800 (1727)
	66.00 (1676.4)	4000 (1818)
60.00 (1524.0)	72.00 (1828.8)	4200 (1909)
	78.00 (1981.2)	4400 (2000)
	84.00 (2133.6)	4600 (2091)
	90.00 (2286.0)	4800 (2182)

**Auxiliary/Transition Structures**

12.00 (304.8)	60.00 (1542.0)	475 (216)
	66.00 (1676.4)	500 (227)
	72.00 (1828.8)	525 (239)
	78.00 (1981.2)	550 (250)
18.00, 22.00 and 24.00 (457.2, 558.8 and 609.6)	84.00 (2133.6)	575 (261)
	90.00 (2286.0)	600 (273)
	60.00 (1542.0)	950 (432)
	66.00 (1676.4)	1000 (455)
30.00 (762.0)	72.00 (1828.8)	1050 (477)
	78.00 (1981.2)	1100 (500)
	84.00 (2133.6)	1150 (523)
	90.00 (2286.0)	1200 (545)
30.00 (762.0)	60.00 (1542.0)	1700 (773)
	66.00 (1676.4)	1750 (795)
	72.00 (1828.8)	1800 (818)
	78.00 (1981.2)	1850 (840)
30.00 (762.0)	84.00 (2133.6)	1900 (864)
	90.00 (2286.0)	1950 (886)

**Utility Structures**

38.00 (965.2)	60.00 (1542.0)	1600 (726)
	66.00 (1676.4)	1625 (738)
	72.00 (1828.8)	1650 (749)
	78.00 (1981.2)	1675 (760)
50.00 (1270.0)	84.00 (2133.6)	1700 (772)
	90.00 (2286.0)	1725 (783)
	60.00 (1542.0)	1650 (749)
	66.00 (1676.4)	1675 (760)
50.00 (1270.0)	72.00 (1828.8)	1700 (772)
	78.00 (1981.2)	1725 (783)
	84.00 (2133.6)	1750 (795)
	90.00 (2286.0)	1775 (806)

① See **Table 20.7-12** on the following page for breaker weights.

**Table 20.7-12. Magnum PXR Front-Access Construction Switchgear Structure Approximate Weights (Less Breakers) ①**

Width in Inches (mm)	Depth in Inches (mm)	Approximate Weight in lb (kg)
<b>Breaker Structure</b>		
18.00, 22.00 and 24.00 (457.2, 558.8 and 609.6)	40.00 (1016.0)	1100 (500)
30.00 (762.0)	40.00 (1016.0)	1750 (795)
44.00 (1117.6)	40.00 (1016.0)	2200 (1000)
<b>Cable Compartment</b>		
18.00, 22.00 and 24.00 (457.2, 558.8 and 609.6)	40.00 (1016.0)	800 (363)
30.00 (762.0)	40.00 (1016.0)	1550 (705)
44.00 (1117.6)	40.00 (1016.0)	1600 (727)

① See Table 20.7-11 for breaker weights.

**Table 20.7-13. Magnum Circuit Breakers with Power Xpert Release Trip Units Weights**

Breaker	Drawout in lb (kg)
<b>Narrow</b>	
MPN-408	130 (59)
MPN-508	130 (59)
MPN-608	130 (59)
MPN-C08	145 (66)
MPN-416	130 (59)
MPN-516	130 (59)
MPN-616	130 (59)
MPN-C16	145 (66)
MPN-620	145 (66)
MPN-C20	145 (66)
<b>Standard</b>	
MPS-408	130 (59)
MPS-608	130 (59)
MPS-808	145 (66)
MPS-C08	145 (66)
MPS-616	130 (59)
MPS-816	145 (66)
MPS-C16	145 (66)
MPS-620	145 (66)
MPS-820	145 (66)
MPS-C20	145 (66)
MPS-632	175 (79)
MPS-832	175 (79)
MPS-C32	175 (79)
<b>Double Wide</b>	
MPN-640	310 (141)
MPN-840	310 (141)
MPN-C40	310 (141)
MPS-840	310 (141)
MPS-C40	310 (141)
MPS-850	310 (141)
MPS-C50	310 (141)
MPS-C60	310 (141)

**Note:** Impact weight equals 1.5 times breaker static weight. Three-pole frame weight given; four-pole frame weight equals 1.33 times more.

**Service Conditions**

**Standards**

Magnum circuit breakers with PXR meet or exceed all applicable requirements of IEEE Standards C37.13, C37.17, ANSI C37.50 and CSA.

**System Voltage and Frequency**

Magnum circuit breakers with PXR are designed for operation on AC systems only, 60 Hz or 50 Hz, 635 V maximum.

**Continuous Current Ratings**

Unlike transformers, generators and motors, circuit breakers are maximum-rated devices and have no built-in temporary overload current ratings. Consequently, it is vital that each application take into consideration the maximum anticipated current demand, initial and future, including temporary overloads.

The continuous rating of any Magnum circuit breaker with PXR is limited to the sensor rating or the frame size current rating, whichever is the lesser. For instance, an MPS-616 1600 A frame breaker with 800 A sensors has a maximum continuous rating of 800 A, but the same breaker with 1600 A sensors is limited to 1600 A maximum.

All current ratings are based on a maximum ambient air temperature of 40 °C (104 °F).

**Ambient Temperature**

The temperature of the air surrounding the enclosure should be within the limits of: -30 °C (-22 °F) to +40 °C (+104 °F).

**Altitude**

The breakers are applicable at their full voltage and current ratings up to a maximum altitude of 6600 ft (2012 m) above sea level. When installed at higher altitudes, the ratings are subject to the following correction factors in accordance with IEEE C37.20.1.

**Table 20.7-14. Altitude Derating Factors**

Altitude		Voltage Correction	Current Correction
Feet	Meters		
6600	2012	1000	1000
7000	2134	0.989	0.998
7500	2286	0.976	0.995
8000	2438	0.963	0.993
8500	2591	0.950	0.990
9000	2743	0.933	0.987
9500	2896	0.917	0.983
10,000	3048	0.900	0.980
10,500	3200	0.883	0.977
11,000	3353	0.867	0.973
11,500	3505	0.850	0.970
12,000	3658	0.833	0.967
12,500	3810	0.817	0.963
13,000	3962	0.800	0.960

All low-voltage air power circuit breakers are tested per the ANSI Standard C37.1 for a system X/R ratio of 6.6 maximum. It is common within low-voltage systems to experience power factor and X/R values outside the range of the standard values, and thus a means to evaluate published product ratings is necessary.

For applications of power breakers within distribution systems having calculated X/R ratios higher than 6.6, the derating of the air power breakers kAIC rating is required. Per IEEE sanctioned methodology, the calculated short circuit current at the point of interest is increased by the **Table 20.7-15** multiplying factors (MF) to yield an “apparent value of short circuit current,” which is then compared to the published breaker ratings. Only breakers having published ratings higher than the “apparent fault current” can be safely applied.

For example, if unfused air power breakers rated 65 kAIC were being considered within a 480/277 Vac distribution system where the X/R at the point of breaker application is 14.25 and the calculated fault current was determined to be 60 kA, the determination of the suitability of these breakers yields:

$$\begin{aligned} \text{Apparent Fault Current} &= 60 \text{ kA} \times \text{MF} \\ &= 60 \text{ kA} \times 1.112 \\ &= 66.72 \text{ kA} \end{aligned}$$

and therefore because 66.72 kA exceeds the 65 kAIC rating, the breakers are not adequate and higher rated kAIC breakers would need to be applied.

**Table 20.7-15. Air Power Breaker Derating**

System X/R Ratio	System % PF	Derating and Multiplying Factors for Air Power Breakers			
		Fused		Unfused	
		Derating	MF	Derating	MF
1.73	50.0	1.000	1.000	1.000	1.000
3.18	30.0	1.000	1.000	1.000	1.000
3.87	25.0	1.000	1.000	1.000	1.000
4.90	20.0	1.000	1.000	1.000	1.000
6.59	15.0	0.939	1.065	1.000	1.000
8.27	12.0	0.898	1.114	0.962	1.000
9.95	10.0	0.870	1.149	0.937	1.067
11.72	8.5	0.849	1.178	0.918	1.089
14.25	7.0	0.827	1.209	0.899	1.112
19.97	5.0	0.797	1.255	0.874	1.144

### Unusual Environmental and Operating Conditions

Special attention should be given to applications subject to the following conditions:

1. Damaging or hazardous fumes, vapors, etc.
2. Excessive or abrasive dust.

For such conditions, it is generally recommended that the switchgear be installed in a clean, dry room, with filtered and/or pressurized clean air. This method permits the use of standard indoor switchgear and avoids the derating effect of non-ventilated enclosures.

3. Salt spray, excessive moisture, dripping, etc.

Drip shields in equipment rooms and space heaters in indoor weatherproof enclosures, may be indicated, depending upon the severity of the conditions.

4. Excessively high or low ambient temperatures.

For ambient temperatures exceeding 40 °C, and based on a standard temperature rise of 65 °C, the continuous current ratings of breaker frame sizes, and also buses, current transformers, etc., will be subject to a derating factor calculated from the following formula:

$$\sqrt{\frac{105^\circ \text{ Total} - \text{Special Ambient, } ^\circ\text{C}}{105^\circ \text{ Total} - 40^\circ \text{C Standard Ambient}}}$$

Circuit breakers are not adversely affected by very low outdoor ambient temperatures, particularly when energized and carrying load currents. The standard space heaters in weatherproof switchgear will raise the temperature slightly and prevent condensation.

Electrical components such as relays and instruments, however, must be applied within the manufacturer's specified limits.

5. Exposure to seismic shock.

Magnum PXR assemblies and breakers have been certified for applications through International Building Code 2021 (IBC) and California Building Code 2019 (CBC). Assembly modifications may be required, so such conditions must be specified.

6. Abnormally high frequency of operation.

In line with above, a lesser number of operations between servicing, and more frequent replacement of parts, may be indicated.

**Eaton**  
1000 Eaton Boulevard  
Cleveland, OH 44122  
United States  
Eaton.com

© 2025 Eaton  
All Rights Reserved  
Printed in USA  
Publication No. DG019008EN / Z30186  
April 2025